

Grove Manitowoc National Crane Potain



Grove GMK5275

Product Guide



Features

- 13,3 m - 68 m (44 ft - 223 ft) seven-section full power MEGAFORM™ boom with TWIN-LOCK™ pinning
- 12 m - 21 m (39 ft - 69 ft) hydraulic offset bi-fold swingaway
- 2 x 8 m (26 ft) intermediate lattice inserts
- 77 t (169,700 lb) counterweight with hydraulic removal system
- MEGATRAK™ independent hydro-pneumatic suspension



Features

MEGATRAK™

The MEGATRAK™ suspension system is the best off road driveline available on the market today. The system's versatility and performance allows the GMK5275 to operate as a true all-terrain crane. The MEGATRAK™ independent suspension and all-wheel steer system allows wheels to remain on the ground at all times so stresses and weight are not continually transferred between axles. MEGATRAK™ provides true ground clearance where others just raise the chassis.

Other benefits of the MEGATRAK™ system are:

- A reliable suspension system
- Excellent job site maneuverability with all-wheel steering
- Commonality among almost all models
- A driveline that remains aligned at all times
- A steering linkage system that is protected against damage
- Constant tire contact for equal tire wear
- Reduced maintenance



CraneSTAR

CraneSTAR is an exclusive and innovative crane asset management system that helps improve your profitability and reduce costs by remotely monitoring critical crane data. Visit www.cranestar.com for more information.

ECOS

Electronic Crane Operating System - ECOS enables control of the entire crane's principle operations. Simple programming eases lift planning and a supply of essential information allows full concentration on the lift itself.



TWIN-LOCK™

Boom pinning mechanism automatically pins the sections in position using two horizontal pins.



2



EKS 5

The EKS 5 monitors the lifting conditions of the crane at all times and provides a full graphic display, rear lighting, graphic of boom telescoping percentage, and load charts.



Contents

Specifications (North American machine)	4
Dimensions (North American machine)	7
Weights (North American machine)	8
Specifications (European machine)	9
Dimensions (European machine)	12
Weights (European machine)	13
Counterweight	14
Working range (main boom)	15
Load charts (main boom)	16
Working range (swingaway)	19
Load charts (hydraulically offsettable swingaway)	20
Working range (heavy duty jib)	23
Load charts (heavy duty jib)	24
Symbols glossary	26

Specifications North American version

Superstructure



Boom

13,3 m - 68 m (44 ft - 223 ft) 7-section, full power MEGAFORM™ boom with TWIN-LOCK™ Pinning.
Maximum tip height: 71 m (233 ft).



Boom nose

Eight nylon sheaves, mounted on heavy duty tapered roller bearings with removable pin-type rope guards. Quick reeve boom nose. Removable auxiliary boom nose with removable pin type rope guard.



Boom elevation

Single lift cylinder with safety valve provides boom angle from -1.5° to +83°.



*Hydraulic offsettable lattice extension

12 m - 21 m (39 ft - 69 ft) bi-fold lattice swingaway extension, hydraulically offsettable and luffing under load, 5°- 40°.
Maximum tip height: 92 m (302 ft)



*Lattice inserts

2 x 8 m (26 ft) inserts for use with lattice swingaway extension to increase length to 29 m (95 ft) or 37 m (121 ft)
Maximum tip height: 108 m (354 ft)



Load moment and anti-two block system

Load moment and anti-two block system with audio/visual warning and control lever lockout provides electronic display of boom angle, length, radius, tip height, relative load moment, maximum permissible load, load indication and warning of impending two-block condition.



Cab

All aluminum constructed cab with acoustical lining, hydraulic tilted to 20°. Includes tinted safety glass, adjustable operator's seat, opening windows at side and rear, hinged windshield with wiper, sun visor and window shade. Other features include hot water heater/defroster, armrest integrated crane controls and ergonomically arranged instrumentation.



Swing

3 planetary gear boxes with fixed displacement axial piston motors. Infinitely variable to 1.3 rpm. Free swing or hydrostatically engaged brake controlled by swing lever. Swing brake selected by foot operated switch.



Counterweight

77 t (169,700 lb) consisting of various sections with hydraulic installation/removal system controlled from the superstructure cab.



Engine

Cummins QSB6.7, 6 cylinder
Horsepower: 164 kW (220 bhp) at 2200 rpm
Torque: 949 Nm (700 ft/lb) at 1500 rpm
Engine emissions: EPA/CARB/EUROMOT (off road)



Fuel tank capacity

230 L (61 gal)



Electrical system

3 phase alternator: 28V/80A
2 batteries: 12V/170Ah



Hydraulic system

3 (three) separate circuits, 1 (one) axial piston variable displacement pump (load sensing) with electronic power limiting control for crane functions and 1 (one) double gear pump for slewing. Thermostatically controlled oil coolers keep oil at optimum operating temperature.
Hydraulic tank capacity: 915 L (242 gal)

Specifications North American version

Superstructure continued

Hoist

Main and auxiliary hoist are powered by axial piston motor with planetary gear and brake. "Thumb-thumper" hoist drum rotation indicator alerts operator of hoist movement.

	Main	Auxiliary
Rope length:	290 m (951 ft)	290 m (951 ft)
Rope diameter:	22 mm	22 mm
Line speed:	125 m/min (410 fpm)	125 m/min (410 fpm)
Line pull:	93.5 kN (21,020 lb)	93.5 kN (21,020 lb)

*Optional equipment

- ▶ Work lights, mounted on boom base section
- ▶ Boom mounted aircraft warning light
- ▶ Radio/CD player for superstructure cab
- ▶ Stainless steel exhaust system with spark arrestor
- ▶ Air conditioning
- ▶ Hook blocks/headache ball
- ▶ Engine independent diesel cab heater, with engine pre-heater. Includes 24 hour timer.
- ▶ Additional cab mounted work light
- ▶ Strobe light
- ▶ Working range limiter
- ▶ Data logger
- ▶ 360° NYC swing lock
- ▶ 2,0 m (6.6 ft) side stowed heavy duty jib with 19 t (41,900 lb) maximum capacity using two parts of line, offset 0° and 25°
- ▶ 2,3 m (7.5 ft) side stowed heavy duty jib with 38 t (83,000 lb) maximum capacity using four parts of line, offset 8° and 30°
- ▶ EKS5 Light semi-graphic display in lieu of standard EKS5

Carrier

Chassis

Box type, torsion resistant frame is fabricated from high strength steel.

Outrigger system

Four hydraulic two stage outrigger beams with vertical cylinders and outrigger pads, 600 mm (23.6 in) square. Outrigger can be set in 5 positions:

Full:	8,1 m (26.6 ft)
Partial:	6,8 m (22.4 ft)
Partial:	5,6 m (18.4 ft)
Partial:	4,4 m (14.4 ft)
Retracted:	2,7 m (9.0 ft)

Independent horizontal and vertical movement controlled from each side of carrier and the superstructure cab. Electronic crane level indicators. Hydraulic disconnect for all outrigger beams.

Transmission

Allison automatic 4000 SP, 6 speeds forward, 1 reverse
2 speed transfer case

Drive/steer

10x6x10

Axles

- 1st axle line – steer
- 2nd axle line – steer/(optional drive)
- 3rd axle line – drive/steer (permanent drive with 10x6, disconnects for highway with 10x8)
- 4th axle line – drive/steer (connects for all wheel steer)
- 5th axle line – drive/steer

Drive axles with planetary hub reduction and center mounted gearing. Standard inter-axle and cross axle differential locks.

Suspension

Grove exclusive MEGATRAK™ suspension. Independent hydro-pneumatic system acting on all wheels with hydraulic lockout. Suspension can be raised 160 mm (6.3 in) or lowered 120 mm (4.7 in), both longitudinally and transversely. Features an automatic leveling system for highway travel.

Specifications North American version

Carrier continued

Tires

10 tires, 16.00R25 (Vehicle width – 3,0 m [9.8 ft])

Steering

Dual circuit, hydraulic power assisted steering system. Transfer case mounted, ground driven emergency steering pump. Axles 1, 2, 3 and 5 steer on highway. Separate steering (steer by wire) of the 4th and 5th axles for all wheel and crab steering, controlled by an electronic rocker switch.

Engine

Cummins QSX15, 6 cylinder
Horsepower: 399 kW (535 bhp) at 2100 rpm
Torque: 2539 Nm (1873 ft/lb) at 1400 rpm
Engine emissions: EPA /CARB/EUROMOT (off road)
Standard compression brake, disconnected when hydraulic transmission retarder is optioned

Fuel tank capacity

397 L (105 gal)

Brakes

Service brakes: pneumatic dual circuit acting on all wheels.
Parking brake: pneumatically operated spring loaded brake acting on axle lines 2, 3, 4 and 5.
Air dryer.

Cab

Two-man, aluminum construction with the following features: safety glass, driver seat with pneumatic suspension, engine-dependent hot water heater, power windows, heated rear view mirrors, complete instrumentation and driving controls.

Electrical system

24V system with three phase alternator, 28V/100A
2 batteries, 12V/170 Ah

Maximum speed

85 km/h (53 mph)

Gradeability (theoretical)

50% - 14.00 tires
45% - 16.00/20.5 tires

Miscellaneous standard equipment

Work light; tool kit; fire extinguishers; auxiliary boom nose; radio/CD player in carrier cab, heated rear view mirrors, wind speed indicator, CraneSTAR asset management system.

*Optional equipment

- ▶ Stainless steel exhaust system with spark arrestor
- ▶ Air conditioning
- ▶ 14.00R25 tires (vehicle width 3 m [9.8 ft])
- ▶ 20.5R25 tires (vehicle width 3,1 m [10.2 ft])
- ▶ 10x8x10 drive/steer
- ▶ Transmission retarder (in lieu of engine compression brake)
- ▶ Engine independent diesel cab heater, with engine pre-heater. Includes 24 hour timer.
- ▶ Strobe light
- ▶ Work lights for outriggers
- ▶ Spare tire and wheel with carry bracket
- ▶ Rear mounted stowage box
- ▶ Outrigger pad load indicator
- ▶ Trailer hitch
- ▶ Steel outrigger pads

Dimensions North American version

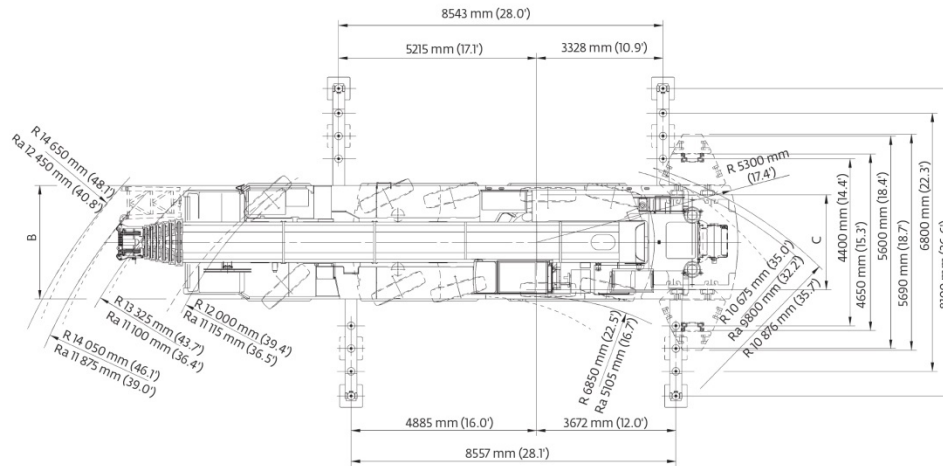
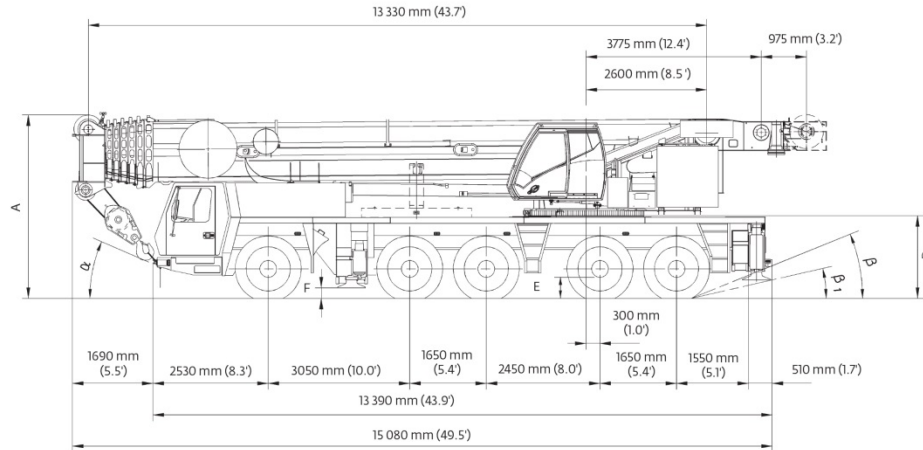

Tires	A	A ^{*10 mm}	B	C	D	E	F	α	β	β ₁
14.00 R25	3950 mm (13')	3820 mm (12.5')	2990 mm (9.8')	2570 mm (8.4')	1780 mm (5.8')	400 mm (1.3')	228 mm (0.7')	23°	22°	13°
16.00 R25	4000 mm (13.1')	3870 mm (12.7')	3000 mm (9.8')	2510 mm (8.2')	1830 mm (6.0')	450 mm (1.5')	258 mm (0.8')	25°	24°	15°
20.5 R25	4000 mm (13.1')	3870 mm (12.7')	3000 mm (9.8')	2530 mm (8.3')	1830 mm (6.0')	450 mm (1.5')	258 mm (0.8')	25°	24°	15°

Ra = Radius all wheels steered
*Lowered

Weights North American version

Trailing boom

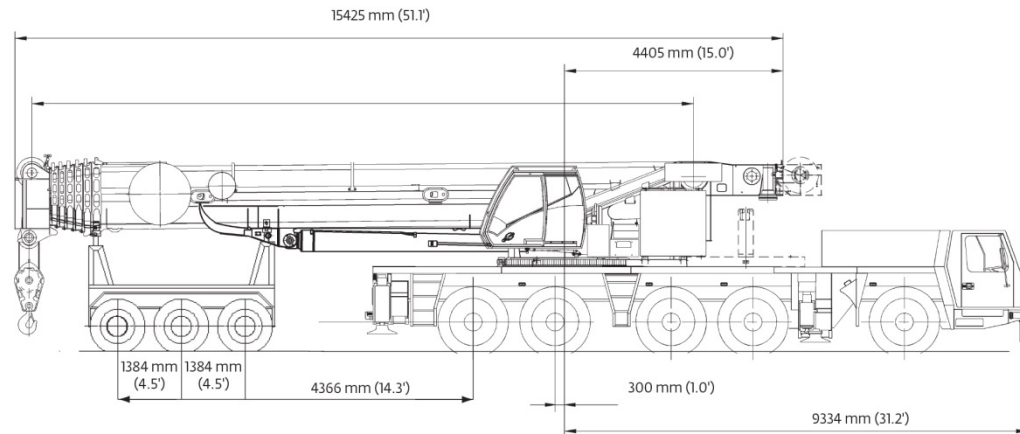

Basic weights - kg (lb)	Axles 1-3		Axles 4 and 5		Dolly		Total	
GMK 5275 Cummins power with: 20.5R25 tires, 10x8x10 drive/steer, 11 m - 18m (36 ft - 59 ft) hydraulic luffing swingaway, 2nd oil cooler, outrigger pads, auxiliary hoist, driver and tanks filled, 3 axle boom dolly (4309 kg / 9400 lb)	30 877	(68,072)	18 123	(39,954)	20 079	(44,267)	69 079	(152,293)
Additions:								
5000 kg (11 000 lb) section pinned to superstructure (special counterweight version)	4845	(10,681)	155	(342)	0	(0)	5000	(11,023)
11 000 kg (24,250 lb) base section stowed on carrier	10 660	(23,501)	340	(750)	0	(0)	11 000	(24,251)
Removals:								
Brackets for hydraulic swingaway incl. hose reel	- 9	(-20)	- 4	(-9)	- 257	(-567)	- 270	(-595)
11 m - 18 m (36 ft - 59 ft) hydraulic swingaway	- 360	(-794)	- 161	(-355)	- 1489	(-3283)	- 2010	(-4431)
Front outriggers	- 2165	(-4773)	275	(606)	0	(0)	- 1890	(-4167)
Rear outriggers	1031	(2273)	- 3371	(-7432)	0	(0)	- 2340	(-5159)
Front and rear outrigger floats	- 70	(-154)	- 130	(-287)	0	(0)	- 200	(-441)
Substitutions:								
10x6x10 drive/steer	- 319	(-703)	- 36	(-79)	0	(0)	- 355	(-783)
14.00R25 tires	- 612	(-1349)	- 408	(-899)	0	(0)	- 1020	(-2249)
16.00R25 tires	- 252	(-556)	- 168	(-370)	0	(0)	- 420	(-926)

Boom over front

Basic Weights - kg (lb)	Axles 1 - 3		Axles 4 and 5		Total	
Cummins power, 16.00R25 tires, 10x6x10 drive/steer, 2nd oil cooler, outrigger pads, driver and tanks filled	37 809	(83,355)	22 126	(48,779)	59 935	(132,134)
Additions:						
10x8x10 drive/steer	319	(703)	36	(79)	355	(783)
Spare wheel 14.00 R25 XGC steel rim with stowage	- 124	(-273)	384	(847)	260	(573)
Spare wheel 16.00 R25 XGC steel rim with stowage	- 153	(-337)	473	(1043)	320	(705)
Spare wheel 20.5 R25 XGC steel rim with stowage	- 173	(-381)	535	(1179)	362	(798)
Brackets for hydraulic swingaway	91	(201)	- 11	(-24)	80	(176)
Hose reel + parts for hydraulic swingaway	327	(721)	- 137	(-302)	190	(419)
11 m - 18 m (36 ft - 59 ft) hydraulic swingaway	2295	(5060)	- 285	(-628)	2010	(4431)
Auxiliary hoist	- 1154	(-2544)	2894	(6380)	1740	(3836)
11 000 kg (24,250 lb) base plate stowed on carrier	10 611	(23,393)	339	(747)	10 950	(24,141)
5000 kg (11,000 lb) slab fixed to turntable (special counterweight version)	- 2748	(-6058)	7728	(17,037)	4980	(10,979)
Substitutions:						
14.00R25 tires	- 360	(-794)	- 240	(-529)	- 600	(-1323)
20.5R25 tires	252	(556)	168	(370)	420	(926)
Removals:						
Boom assembly w/o lift cylinder	- 19 776	(-43,599)	- 1359	(-2996)	- 21 135	(-46,595)
Front outriggers	- 2187	(-4822)	277	(611)	- 1910	(-4211)
Rear outriggers	1022	(2253)	- 3342	(-7368)	- 2320	(-5115)
Front and rear outrigger floats	- 70	(-154)	- 130	(-287)	- 200	(-441)

Specifications European version

Superstructure

Boom

13,3 m - 68 m (44 ft - 223 ft) 7-section, full power MEGAFORM™ boom with TWINLOCK™ Pinning. Maximum tip height: 71 m (233 ft)

Boom nose

Eight nylatron sheaves, mounted on heavy duty tapered roller bearings with removable pin-type rope guards. Quick Reeve boom nose. Removable auxiliary boom nose with removable pin type rope guard.

Boom elevation

Single lift cylinder with safety valve provides boom angle from -1.5° to +83°.

*Hydraulic offsettable lattice extension

12 m - 21 m (39 ft - 69 ft) bi-fold lattice swingaway extension, hydraulically offsettable and luffing under load, 5°- 40°.

Maximum tip height: 92 m (302 ft)

*Lattice inserts

2 x 8 m (26 ft) inserts for use with lattice swingaway extension to increase length to 29 m (95 ft) or 37 m (121 ft)

Maximum tip height: 108 m (354 ft)

Load moment and anti-two block system

Load moment and anti-two block system with audio/visual warning and control lever lockout provides electronic display of boom angle, length, radius, tip height, relative load moment, maximum permissible load, load indication and warning of impending two-block condition.

Cab

All aluminum constructed cab with acoustical lining, hydraulic tilted to 20°. Includes tinted safety glass, adjustable operator's seat, opening windows at side and rear, hinged windshield with wiper, sun visor and window shade. Other features include diesel heater/defroster, armrest integrated crane controls and ergonomically arranged instrumentation.

Swing

3 planetary gear boxes with fixed displacement axial piston motors. Infinitely variable to 1.3 rpm. Free swing or hydrostatically engaged brake controlled by swing lever. Swing brake selected by foot operated switch.

Counterweight

77 t (169,700 lb) consisting of various sections with hydraulic installation/removal system controlled from the superstructure cab.

Engine

Mercedes OM 906 LA, 6 cylinder
Horsepower: 170 kW (228 bhp) at 2200 rpm
Torque: 810 Nm (597 ft/lb) at 1200 rpm
Engine emissions: EPA/CARB/EUROMOT (off road)

Fuel tank capacity

Supplied from chassis fuel tank.

Electrical system

3 phase alternator: 28V/80A
2 batteries: 12V/170Ah

Hydraulic system

2 separate circuits, 1 axial piston variable displacement pump (load sensing) with electronic power limiting control for crane functions and 1 double gear pump for slewing. Thermostatically controlled oil coolers keep oil at optimum operating temperature.

Hydraulic tank capacity: 915 L (242 gal)

Specifications European version

Superstructure continued

Hoist

Main and auxiliary hoist are powered by axial piston motor with planetary gear and brake. "Thumb-thumper" hoist drum rotation indicator alerts operator of hoist movement.

	Main	Auxiliary
Rope length:	290 m (951 ft)	290 m (951 ft)
Rope diameter:	22 mm	22 mm
Line speed:	125 m/min (410 fpm)	125 m/min (410 fpm)
Line pull:	93.5 kN (21,020 lb)	93.5 kN (21,020 lb)

*Optional equipment

- ▶ Work lights, mounted on boom base section
- ▶ Boom mounted aircraft warning light
- ▶ Radio/CD player for superstructure cab
- ▶ Stainless steel exhaust system with spark arrestor
- ▶ Air conditioning
- ▶ Hook blocks/headache ball
- ▶ Engine independent diesel cab heater, with engine pre-heater. Includes 24 hour timer.
- ▶ Additional cab mounted work light
- ▶ Strobe light
- ▶ Working range limiter
- ▶ Data logger
- ▶ 360° NYC swing lock
- ▶ 2,0 m (6.6 ft) side stowed heavy duty jib with 19 t (41,900 lb) maximum capacity using two parts of line, offset 0° and 25°
- ▶ 2,3 m (7.5 ft) side stowed heavy duty jib with 38 t (83,000 lb) maximum capacity using four parts of line, offset 8° and 30°
- ▶ EKS5 Light semi-graphic display in lieu of standard EKS5

Carrier

Chassis

Box type, torsion resistant frame is fabricated from high strength steel.

Outrigger system

Four hydraulic two stage outrigger beams with vertical cylinders and outrigger pads, 600 mm (23.6 in) square. Outrigger can be set in 5 positions:

Full:	8,1 m (26.6 ft)
Partial:	6,8 m (22.3 ft)
Partial:	5,6 m (18.4 ft)
Partial:	4,4 m (14.4 ft)
Retracted:	2,7 m (9.0 ft)

Independent horizontal and vertical movement controlled from each side of carrier and the superstructure cab. Electronic crane level indicators. Hydraulic disconnect for all outrigger beams

Transmission

Allison automatic 4000 SP, 6 speeds forward, 1 reverse
2 speed transfer case

Drive/steer

10 x 6 x 10

Axles

- 1st axle line – steer
- 2nd axle line – steer/(optional drive)
- 3rd axle line – drive/steer (permanent drive with 10 x 6, disconnects for highway with 10 x 8)
- 4th axle line – drive/steer (connects for all wheel steer)
- 5th axle line – drive/steer

Drive axles with planetary hub reduction and center mounted gearing. Standard inter-axle and cross axle differential locks.

Suspension

Grove exclusive MEGATRAK™ suspension. Independent hydro-pneumatic system acting on all wheels with hydraulic lockout. Suspension can be raised 160 mm (6.3 in) or lowered 120 mm (4.7 in), both longitudinally and transversely. Features an automatic leveling system for highway travel.

Specifications European version

Carrier continued

Tires

10 tires, 16.00R25 (Vehicle width – 3,0 m [9.8 ft])

Steering

Dual circuit, hydraulic power assisted steering system. Transfer case mounted, ground driven emergency steering pump. Axles 1, 2, 3 and 5 steer on highway. Separate steering (steer by wire) of the 4th and 5th axles for all wheel and crab steering, controlled by an electronic rocker switch.

Engine

Mercedes OM 502 LA, 8 cylinder
Horsepower: 420 kW (563 bhp) at 1800 rpm
Torque: 2700 Nm (1991 ft/lb) at 1200 rpm
Engine emissions: EPA/CARB/EUROMOT (off road)

Fuel tank capacity

515 L (136 gal). Supplies superstructure and carrier engines.

Brakes

Service brakes: pneumatic dual circuit acting on all wheels.
Parking brake: pneumatically operated spring loaded brake acting on axle lines 2, 3, 4 and 5.
Air dryer

Cab

Two-man, aluminum construction with the following features: safety glass, driver seat with pneumatic suspension, engine-dependent hot water heater, power windows, heated rear view mirrors, complete instrumentation and driving controls.

Electrical system

24V system with three phase alternator, 28V/100A
2 batteries, 12V/170 Ah

Maximum speed

85 km/h (53 mph)

Gradeability (theoretical)

50% - 14.00 tires
45% - 16.00/20.5 tires

Miscellaneous standard equipment

Work light; tool kit; fire extinguishers; auxiliary boom nose; radio /CD player in carrier cab, heated rear view mirrors, wind speed indicator.

*Optional equipment

- ▣ Stainless steel exhaust system with spark arrestor
- ▣ Air conditioning
- ▣ 14.00R25 tires (vehicle width. 3 m [9.8 ft])
- ▣ 20.5R25 tires (vehicle width. 3,1 m [10.2 ft])
- ▣ 10x8x10 drive/steer
- ▣ Transmission retarder (in lieu of engine compression brake)
- ▣ Engine independent diesel cab heater, with engine pre-heater. Includes 24 hour timer.
- ▣ Strobe light
- ▣ Work lights for outriggers
- ▣ Spare tire and wheel with carry bracket
- ▣ Rear mounted stowage box
- ▣ Outrigger pad load indicator
- ▣ Trailer hitch
- ▣ Steel outrigger pads

Dimensions European version

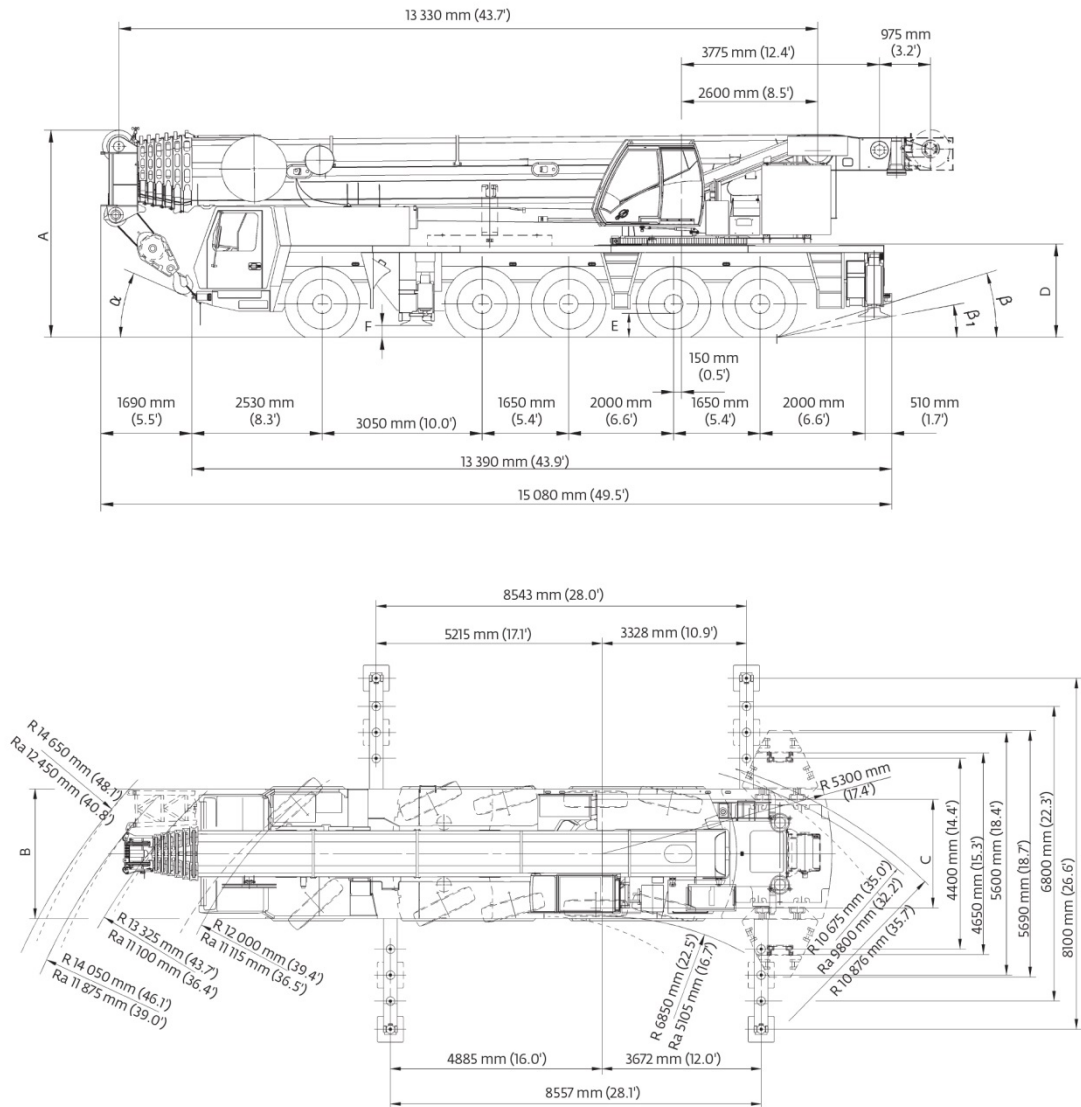

Tires	A	A ^{*100 mm (0.4)}	B	C	D	E	F	α	β	β ₁
14.00 R25	3950 mm (13')	3820 mm (12.5')	2990 mm (9.8')	2570 mm (8.4')	1780 mm (5.8')	400 mm (1.3')	228 mm (0.7')	23°	15°	10°
16.00 R25	4000 mm (13.1')	3870 mm (12.7')	3000 mm (9.8')	2510 mm (8.2')	1830 mm (6.0')	450 mm (1.5')	258 mm (0.8')	25°	17°	12°
20.5 R25	4000 mm (13.1')	3870 mm (12.7')	3000 mm (9.8')	2530 mm (8.3')	1830 mm (6.0')	450 mm (1.5')	258 mm (0.8')	25°	17°	12°

Ra = Radius all wheels steered
*Lowered

Weights European version

Trailing boom

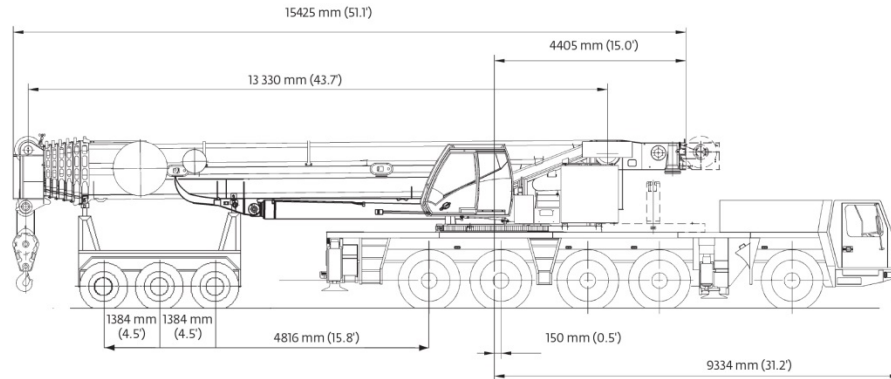

Basic weights - kg (lb)	Axles 1-3		Axles 4 and 5		Dolly		Total	
GMK 5275 Mercedes power with: 20.5R25 tires, 10x8x10 drive/steer, 11 m-18m (36-59 ft) hydraulic luffing swingaway, 2nd oil cooler, outrigger pads, auxiliary hoist, driver and tanks filled, 3 axle boom dolly (4309 kg / 9400 lb)	27 881	(61,467)	20 119	(44,355)	20 079	(44,267)	68 079	(150,089)
Additions:								
5000 kg (11 000 lb) section pinned to superstructure (special counterweight version)	4831	(10,651)	169	(373)	0	(0)	5000	(11,023)
11 000 kg (24,250 lb) base section stowed on carrier	10 629	(23,433)	371	(818)	0	(0)	11 000	(24,251)
Removals:								
Brackets for hydraulic swingaway incl. hose reel	- 8	(-18)	- 4	(-9)	- 257	(-567)	- 270	(-595)
11 m - 18 m (36 ft - 59 ft) hydraulic swingaway	- 345	(-761)	- 176	(-388)	-1489	(-3283)	-2010	(-4431)
Front outriggers	-2190	(-4828)	300	(661)	0	(0)	-1890	(-4167)
Rear outriggers	1338	(2950)	-3678	(-8109)	0	(0)	-2340	(-5159)
Front and rear outrigger floats	- 59	(-130)	- 141	(-311)	0	(0)	- 200	(-441)
Substitutions:								
10x6x10 drive/steer	- 316	(-697)	- 39	(-86)	0	(0)	- 355	(-783)
14.00R25 tires	- 612	(-1349)	- 408	(-899)	0	(0)	-1020	(-2249)
16.00R25 tires	- 252	(-556)	- 168	(-370)	0	(0)	- 420	(-926)

Basic weights - kg (lb)	Axles 1 - 3		Axles 4 and 5		Total	
Mercedes power, 16.00R25 tires, 10x6x10 drive/steer, 2nd oil cooler, outrigger pads, driver and tanks filled	34 340	(75,707)	24 645	(54,333)	58 985	(130,040)
Additions:						
10x8x10 drive/steer	316	(697)	39	(86)	355	(783)
Spare wheel 14.00 R25 XGC steel rim with stowage	- 186	(-410)	446	(983)	260	(573)
Spare wheel 16.00 R25 XGC steel rim with stowage	- 229	(-505)	549	(1210)	320	(705)
Spare wheel 20.5 R25 XGC steel rim with stowage	- 259	(-571)	621	(1369)	362	(798)
Brackets for hydraulic swingaway	92	(203)	- 12	(-26)	80	(176)
Hose reel + parts for hydraulic swingaway	339	(747)	- 149	(-328)	190	(419)
11 m - 18 m (36 ft - 59 ft) hydraulic swingaway	2321	(5117)	- 311	(-686)	2010	(4431)
Auxiliary hoist	-1417	(-3124)	3157	(6960)	1740	(3836)
11 000 kg (24,250 lb) base plate stowed on carrier	10 581	(23,327)	369	(814)	10 950	(24,141)
5000 kg (11,000 lb) slab fixed to turntable (special counterweight version)	-3452	(-7610)	8432	(18,589)	4980	(10,979)
Substitutions:						
14.00R25 tires	- 360	(-794)	- 240	(-529)	- 600	(-1323)
20.5R25 tires	252	(556)	168	(370)	420	(926)
Removals:						
Boom assembly w/o lift cylinder	-19 612	(-43,237)	-1523	(-3358)	-21 135	(-46,595)
Front outriggers	-2213	(-4879)	303	(668)	-1910	(-4211)
Rear outriggers	1326	(2923)	-3646	(-8038)	-2320	(-5115)
Front and rear outrigger floats	- 59	(-130)	- 141	(-311)	- 200	(-441)

Counterweight

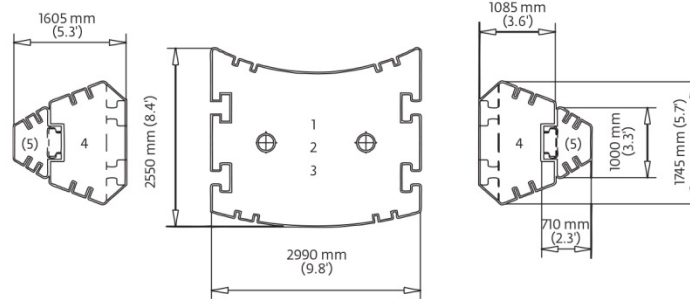
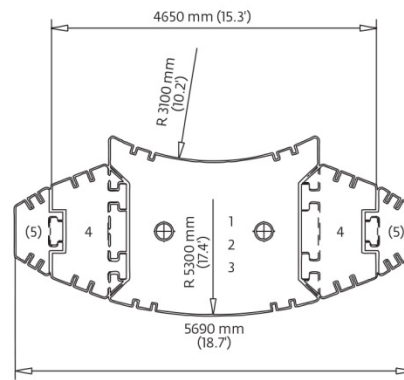
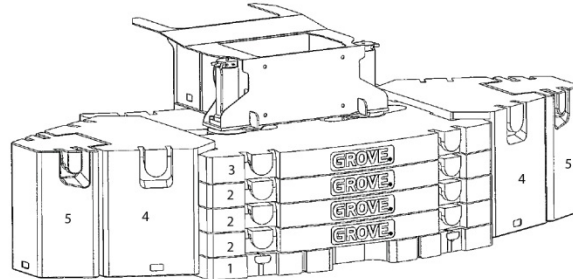

Counterweight Configuration kg (lb)

	1 (Baseplate)	2 (Stackable)	3 (Stackable)	4 (Wing)	5 (Wing)
	11 000 (24,200)	10 000 (22,046)	10 000 (22,046)	10 000 (22,046)	3000 (6600)
11 000 (24,200)	•				
21 000 (46,200)	•	•			
31 000 (68,300)	•	X2			
41 000 (90,300)	•	X3			
51 000 (112,400)	•	X3	•		
71 000 (156,500)	•	X3	•	X2	
77 000 (169,700)	•	X3	•	X2	X2

Working range

44 ft - 223 ft main boom

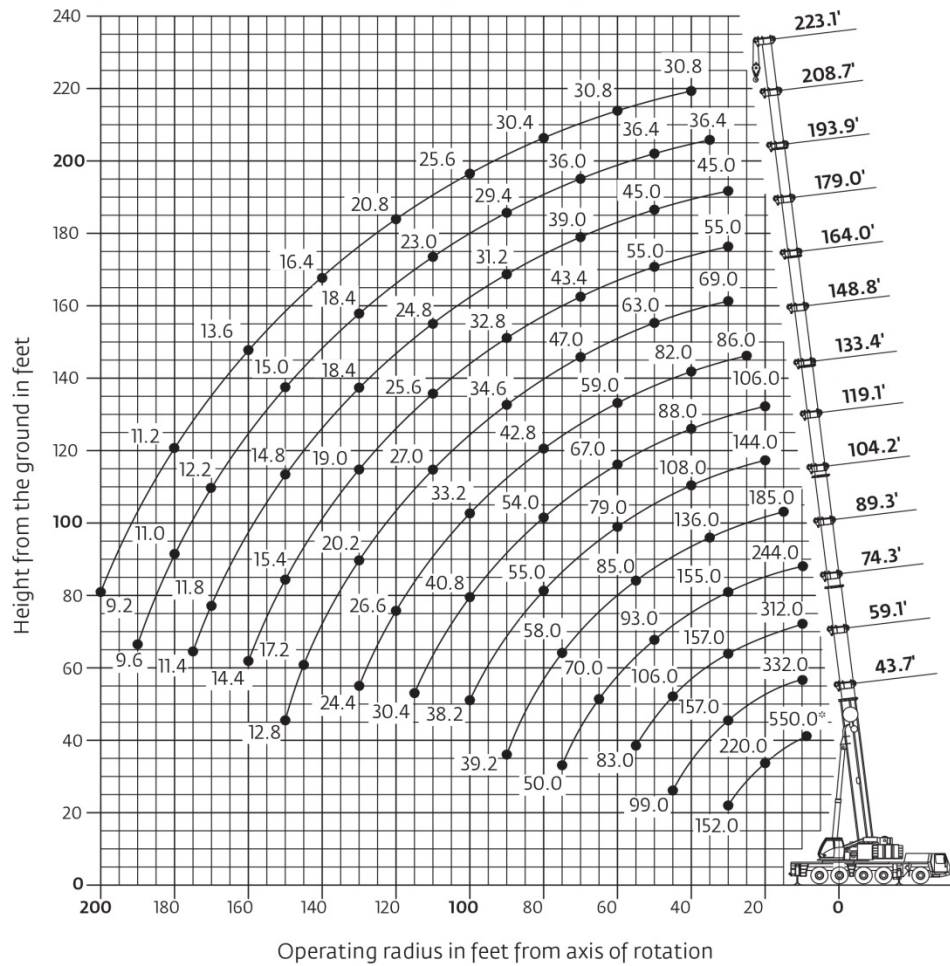

Hook block	H
200 ton, 9 sheave	12.0 ft (3650 mm)
160 ton, 7 sheave	12.0 ft (3650 mm)
125 ton, 5 sheave	10.8 ft (3300 mm)
80 ton, 3 sheave	10.8 ft (3300 mm)
32 ton, 1 sheave	10.5 ft (3200 mm)
12 ton, single line headache ball	8.0 ft (2450 mm)

Grove GMK5275 *THIS CHART IS ONLY A GUIDE AND SHOULD NOT BE USED TO OPERATE THE CRANE. The individual crane's load chart, operating instructions and other instructional plates must be read and understood prior to operating the crane*

Load charts Main boom

 13,3 m - 68 m
(44 ft - 223 ft)
  77 000 kg
(169,700 lb)
  26 ft 7 in spread
(100%)
  360°

Pounds x 1000



Feet	43.7'	59.1'	74.3'	89.3'	104.2'	119.1'	133.4'	148.8'	164.0'	179.0'	193.9'	208.7'	223.1'
8	550.0												
10	346.0												
15	272.0	270.0	260.0	242.0	185.0								
20	220.0	222.0	215.0	212.0	182.0								
25	184.0	185.0	181.0	181.0	166.0	140.0	106.0						
30	152.0	157.0	157.0	155.0	151.0	129.0	105.0	86.0					
35		136.0	136.0	135.0	136.0	118.0	96.0	86.0	69.0	55.0	45.0		
40		121.0	119.0	118.0	120.0	108.0	88.0	82.0	69.0	55.0	45.0	36.4	
45		99.0	106.0	104.0	106.0	99.0	81.0	75.0	68.0	55.0	45.0	36.4	30.8
50			95.0	93.0	95.0	92.0	76.0	70.0	63.0	55.0	45.0	36.4	30.8
55			83.0	84.0	85.0	85.0	72.0	64.0	59.0	52.0	45.0	36.4	30.8
60				76.0	77.0	79.0	67.0	59.0	54.0	49.0	44.0	36.4	30.8
65				70.0	70.0	72.0	63.0	54.0	50.0	46.0	41.2	36.4	30.8
70				63.0	64.0	66.0	60.0	50.0	47.0	43.4	39.0	36.0	30.8
75				58.0	58.0	61.0	57.0	46.0	43.0	40.4	36.8	34.4	30.8
80				53.0	53.0	55.0	54.0	42.8	39.6	37.6	34.8	32.6	30.4
85				49.0	49.0	51.0	51.0	40.2	37.2	35.2	33.0	31.0	29.2
90					39.2	46.0	48.0	37.6	34.6	32.8	31.2	29.4	28.0
95						42.4	44.0	35.2	32.4	30.8	29.4	28.0	26.8
100							38.2	40.8	33.2	30.4	28.8	27.8	26.4
105								37.6	31.4	28.8	27.2	26.4	24.4
110								34.8	29.6	27.0	25.6	24.8	23.2
115								30.4	28.0	25.2	23.8	23.0	21.4
120									26.6	23.2	21.8	21.2	20.4
125									25.2	21.4	20.0	19.4	19.4
130										24.4	20.2	19.0	18.4
135											19.2	18.0	17.4
140												17.4	16.4
145													16.4
150													16.4
155													15.6
160													15.0
165													14.2
170													13.6
175													13.0
180													12.4
185													11.8
190													11.2
195													10.6
200													10.2

* Over the rear with special equipment

Loads greater than 297,000 lb/335,000 lb can only be lifted with additional special equipment.



Load charts Main boom

 13.3 m - 68 m
(44 ft - 223 ft)
  51 000 kg
(112,400 lb)
  26 ft 7 in spread
(100%)
  360°

  Pounds x 1000

Feet	43.7'	59.1'	74.3'	89.3'	104.2'	119.1'	133.4'	148.8'	164.0'	179.0'	193.9'	208.7'	223.1'
10	336.0	332.0	312.0	244.0									
15	262.0	260.0	258.0	242.0	185.0								
20	210.0	211.0	208.0	210.0	182.0	144.0	106.0						
25	176.0	177.0	176.0	175.0	166.0	140.0	106.0	86.0					
30	149.0	150.0	150.0	148.0	150.0	129.0	105.0	86.0	69.0	55.0	45.0		
35		132.0	130.0	127.0	124.0	118.0	96.0	86.0	69.0	55.0	45.0	36.4	
40		114.0	111.0	110.0	103.0	102.0	88.0	82.0	69.0	55.0	45.0	36.4	30.8
45		98.0	95.0	94.0	90.0	88.0	81.0	75.0	68.0	55.0	45.0	36.4	30.8
50			83.0	82.0	81.0	76.0	76.0	70.0	63.0	55.0	45.0	36.4	30.8
55			72.0	71.0	72.0	67.0	68.0	64.0	59.0	52.0	45.0	36.4	30.8
60				62.0	64.0	62.0	60.0	57.0	54.0	49.0	44.0	36.4	30.8
65				57.0	56.0	58.0	54.0	50.0	49.0	46.0	41.2	36.4	30.8
70				51.0	50.0	52.0	49.0	45.0	43.8	43.2	39.0	36.0	30.8
75				46.0	45.0	47.0	44.0	40.8	39.6	39.0	36.8	34.4	30.8
80					41.6	42.0	40.0	37.0	35.8	35.4	34.8	32.6	30.4
85					39.2	38.2	36.0	34.2	32.4	32.0	32.0	31.0	29.2
90					35.8	34.6	32.6	32.8	29.4	29.2	29.2	29.4	28.0
95						31.4	29.4	31.4	26.8	26.6	26.6	27.4	26.8
100						28.8	26.8	28.6	24.4	24.4	24.4	25.0	25.6
105							25.2	26.0	22.2	22.8	22.2	23.0	23.6
110							24.2	23.8	20.0	21.2	20.4	21.2	21.8
115							23.4	21.8	18.4	20.2	19.0	19.4	20.2
120								20.0	17.8	19.4	18.0	18.6	18.6
125								18.4	17.0	18.4	17.2	17.6	17.2
130								16.8	16.2	17.8	16.4	16.6	15.8
135									15.6	16.8	15.8	15.8	14.6
140									15.0	15.4	15.0	14.8	13.4
145										14.4	14.2	13.6	12.4
150										13.2	13.2	12.6	11.2
155										12.2	12.2	11.4	10.2
160										11.4	11.2	10.6	9.2
165											10.6	9.6	8.4
170											9.8	8.8	7.6
175											9.2	8.0	6.8
180												7.2	6.0
185												6.6	5.2
190												6.0	4.6
195													4.0
200													3.4

 13.3 m - 68 m
(44 ft - 223 ft)
  41 000 kg
(90,300 lb)
  26 ft 7 in spread
(100%)
  360°

  Pounds x 1000

Feet	43.7'	59.1'	74.3'	89.3'	104.2'	119.1'	133.4'	148.8'	164.0'	179.0'	193.9'	208.7'	223.1'
10	332.0	328.0	312.0	244.0									
15	256.0	256.0	254.0	242.0	185.0								
20	207.0	208.0	206.0	206.0	182.0	144.0	106.0						
25	172.0	173.0	173.0	171.0	166.0	140.0	106.0	86.0					
30	146.0	149.0	146.0	138.0	131.0	128.0	105.0	86.0	69.0	55.0	45.0		
35		124.0	117.0	114.0	110.0	105.0	96.0	86.0	69.0	55.0	45.0	36.4	
40		102.0	101.0	95.0	94.0	88.0	87.0	82.0	69.0	55.0	45.0	36.4	30.8
45		84.0	85.0	81.0	80.0	76.0	75.0	71.0	68.0	55.0	45.0	36.4	30.8
50			72.0	72.0	70.0	70.0	65.0	61.0	59.0	55.0	45.0	36.4	30.8
55			64.0	61.0	62.0	57.0	54.0	52.0	54.0	51.0	45.0	36.4	30.8
60				55.0	56.0	55.0	51.0	47.0	46.0	45.0	44.0	36.4	30.8
65				49.0	51.0	49.0	45.0	42.0	40.6	40.0	39.6	36.4	30.8
70				43.6	45.0	44.0	40.6	39.8	36.2	35.6	35.4	36.0	30.8
75				38.4	40.6	39.4	36.4	37.6	32.4	32.0	31.8	32.4	30.8
80					36.6	35.4	33.0	34.0	29.0	29.4	29.2	30.2	29.8
85					33.0	31.6	30.0	31.0	26.4	28.2	27.8	28.6	27.0
90					29.8	28.6	28.6	28.4	25.0	27.0	26.2	26.6	24.6
95						25.8	27.4	25.6	23.2	25.6	24.6	24.4	22.4
100						23.4	25.2	23.2	21.2	24.0	23.0	22.4	20.4
105							22.8	21.0	20.4	22.2	20.8	20.6	18.6
110							21.0	19.0	19.4	20.4	19.8	18.8	17.0
115							19.2	17.2	18.4	18.6	18.4	17.4	15.6
120								16.0	17.8	17.0	17.0	16.0	14.2
125								15.2	17.0	15.8	16.0	14.6	13.0
130								14.6	15.8	15.0	14.6	13.4	11.8
135									14.6	14.2	13.4	12.2	10.6
140									13.4	13.0	12.2	11.2	9.6
145										12.0	11.2	10.0	8.8
150										11.0	10.2	9.0	7.8
155										10.2	9.2	8.2	7.0
160										9.4	8.4	7.4	6.0
165											7.6	6.6	5.2
170											7.0	5.8	4.6
175											6.2	5.2	3.8
180												4.4	3.2
185													3.8
190													3.2

THIS CHART IS ONLY A GUIDE AND SHOULD NOT BE USED TO OPERATE THE CRANE.

Grove GMK5275



The individual crane's load chart, operating instructions and other instructional plates must be read and understood prior to operating the crane



Load charts Main boom

 13.3 m - 68 m
(44 ft - 223 ft)
  21 000 kg
(46,200 lb)
  26 ft 7 in spread
(100%)
  360°

 Pounds x 1000

Feet	43.7'	59.1'	74.3'	89.3'	104.2'	119.1'	133.4'	148.8'	164.0'	179.0'	193.9'	208.7'	223.1'
10	320.0	318.0	312.0	244.0									
15	248.0	248.0	245.0	242.0	185.0								
20	199.0	200.0	187.0	175.0	158.0	144.0	106.0						
25	154.0	148.0	138.0	128.0	123.0	113.0	106.0	86.0					
30	114.0	111.0	105.0	103.0	96.0	94.0	87.0	81.0	69.0	55.0	45.0		
35		90.0	87.0	83.0	82.0	77.0	71.0	66.0	63.0	55.0	45.0	36.4	
40		72.0	72.0	68.0	68.0	64.0	59.0	59.0	52.0	51.0	45.0	36.4	30.8
45		58.0	60.0	61.0	58.0	54.0	50.0	51.0	43.8	43.0	42.0	36.4	30.8
50			50.0	52.0	50.0	47.0	45.0	43.4	39.2	40.6	39.6	36.0	30.8
55			45.0	46.0	43.2	40.2	41.2	37.4	36.8	37.4	36.6	34.0	30.8
60				39.2	37.8	36.0	36.0	32.6	34.6	34.0	32.2	29.8	27.4
65				33.8	33.2	33.8	31.8	30.6	31.4	30.2	28.4	26.2	24.0
70				29.4	29.0	30.6	28.2	29.0	28.4	26.8	25.2	23.2	21.0
75				22.8	25.4	27.4	25.0	27.0	25.4	24.0	22.4	20.4	18.4
80					22.2	24.2	23.2	24.4	23.0	21.4	20.0	18.2	16.2
85					22.0	21.4	20.8	22.0	20.6	19.2	17.8	16.0	14.2
90					19.6	19.0	19.4	20.0	18.6	17.2	16.0	14.2	12.4
95						17.4	18.4	18.0	16.8	15.6	14.2	12.6	10.8
100						16.6	16.4	16.2	15.2	14.0	12.6	11.0	9.2
105							14.8	14.6	13.8	12.6	11.2	9.8	8.0
110							13.4	13.0	12.4	11.2	10.0	8.4	6.8
115							12.0	11.6	11.0	10.0	8.8	7.4	5.6
120							10.4	10.4	9.8	9.0	7.8	6.4	4.6
125							9.4	8.6	8.0	6.8	6.8	5.4	3.8
130							8.4	7.6	7.0	6.0	6.0	4.6	2.8
135								6.8	6.0	5.2	5.2	3.8	
140								6.0	5.2	4.4	4.4	3.0	
145									4.4	3.6	3.6		
150									3.6	2.8	2.8		
155									3.0				

 13.3 m - 68 m
(44 ft - 223 ft)
  0 kg
(0 lb)
  26 ft 7 in spread
(100%)
  360°

 Pounds x 1000

Feet	43.7'	59.1'	74.3'	89.3'	104.2'	119.1'	133.4'	148.8'	164.0'	177.6'	192.6'
10	308.0	308.0	286.0	232.0							
15	222.0	185.0	160.0	144.0	125.0						
20	122.0	114.0	105.0	100.0	90.0	79.0	76.0				
25	81.0	80.0	77.0	72.0	65.0	63.0	57.0	56.0			
30	56.0	58.0	57.0	54.0	53.0	49.0	48.0	45.0	41.2	37.6	34.4
35		44.0	44.0	44.0	42.4	41.2	38.8	36.4	33.4	30.6	28.0
40		34.2	35.6	36.0	35.0	33.8	32.0	30.0	27.6	25.2	22.8
45		27.4	28.8	29.6	29.0	28.0	26.6	25.0	23.0	20.8	18.8
50			23.8	24.8	24.2	23.6	22.4	21.0	19.2	17.2	15.4
55			19.8	20.8	20.4	20.0	19.0	17.8	16.2	14.4	12.8
60				17.6	17.4	17.0	16.2	15.0	13.6	12.0	10.4
65				15.0	14.8	14.6	13.8	12.8	11.4	9.8	8.4
70				12.6	12.6	12.4	11.8	10.8	9.4	8.0	6.8
75				5.8	10.8	10.6	10.0	9.2	7.8	6.6	5.2
80					9.2	9.0	8.4	7.6	6.4	5.2	4.0
85					7.6	7.8	7.2	6.4	5.2	4.0	2.8
90					6.2	6.6	6.0	5.2	4.0	2.8	
95						5.4	4.8	4.2	3.0		
100						4.4	4.0	3.2			
105							3.2				

Working range

223 ft main boom with 39 ft and 69 ft swingaway

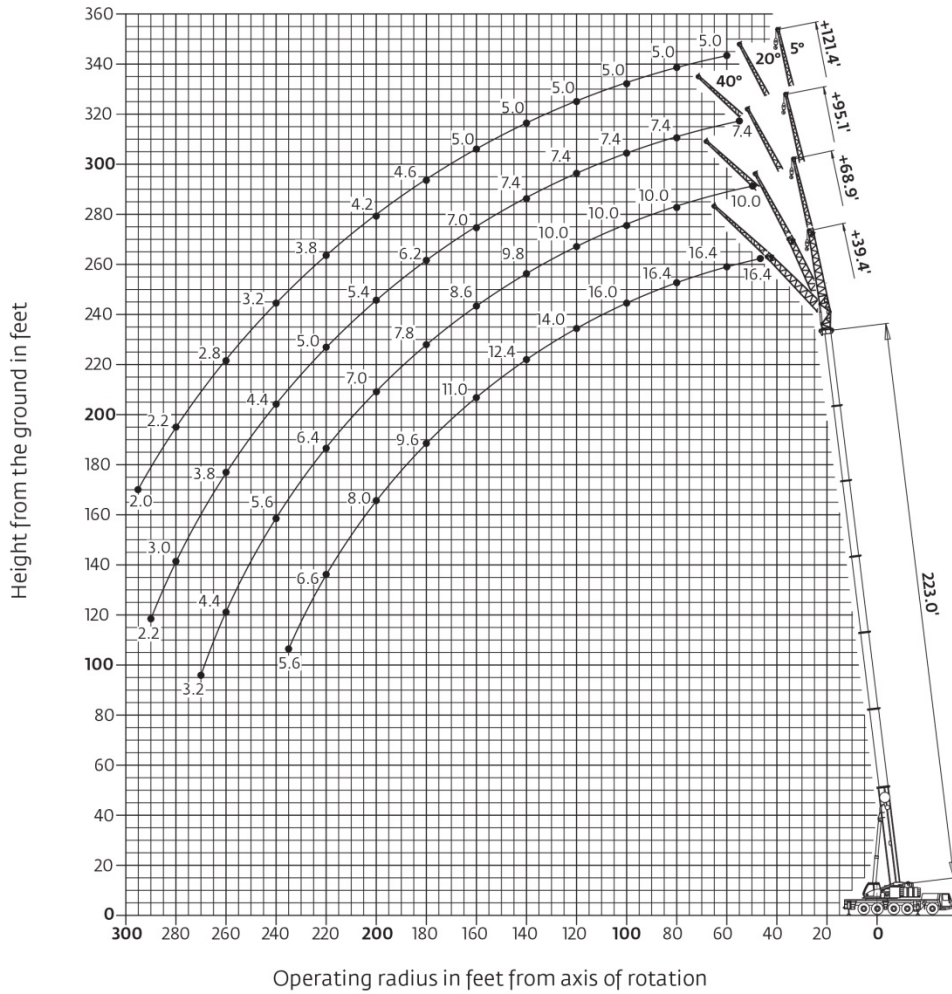

Hook heights shown in the working diagram do not consider loaded boom deflection.



Grove GMK5275 THIS CHART IS ONLY A GUIDE AND SHOULD NOT BE USED TO OPERATE THE CRANE. The individual crane's load chart, operating instructions and other instructional plates must be read and understood prior to operating the crane.

Load charts

Hydraulic offsettable swingaway

Intermediate angle and loads for luffing

 68 m (223 ft)
  12-21-29-37 m (39-69-95-121 ft)
  77 000 kg (169,700 lb)
  26 ft 7 in spread (100%)
  360°

  Pounds x 1000

Radius	223' + 39.4'			223' + 68.9'			223' + 95.1'			223' + 121.4'		
	5°	5° - 20°	20° - 40°	5°	5° - 20°	20° - 40°	5°	5° - 20°	20° - 40°	5°	5° - 20°	20° - 40°
45	16.4											
50	16.4	16.4		10.0								
55	16.4	16.4		10.0			7.4					
60	16.4	16.4	16.4	10.0			7.4			5.0		
65	16.4	16.4	16.4	10.0			7.4			5.0		
70	16.4	16.4	16.4	10.0	10.0		7.4			5.0		
75	16.4	16.4	16.4	10.0	10.0		7.4	7.4		5.0		
80	16.4	16.4	16.4	10.0	10.0		7.4	7.4	7.4	5.0	5.0	
85	16.4	16.4	16.0	10.0	10.0		7.4	7.4	7.4	5.0	5.0	
90	16.4	16.2	15.6	10.0	10.0	9.4	7.4	7.4	7.4	5.0	5.0	
95	16.4	15.8	15.2	10.0	10.0	9.4	7.4	7.4	7.2	5.0	5.0	4.0
100	16.0	15.2	14.8	10.0	10.0	9.2	7.4	7.4	7.2	5.0	5.0	4.0
105	15.6	14.8	14.4	10.0	10.0	9.2	7.4	7.4	7.2	5.0	5.0	4.0
110	15.0	14.4	14.0	10.0	10.0	9.2	7.4	7.4	7.2	5.0	5.0	4.0
115	14.4	13.8	13.6	10.0	10.0	9.0	7.4	7.4	7.2	5.0	5.0	4.0
120	14.0	13.4	13.2	10.0	10.0	9.0	7.4	7.4	7.2	5.0	5.0	4.0
125	13.6	13.0	12.8	10.0	10.0	9.0	7.4	7.4	7.2	5.0	5.0	4.0
130	13.2	12.6	12.4	10.0	9.8	8.8	7.4	7.4	7.2	5.0	5.0	4.0
135	12.8	12.2	12.2	10.0	9.6	8.8	7.4	7.4	7.2	5.0	5.0	4.0
140	12.4	12.0	11.8	9.8	9.4	8.8	7.4	7.2	7.0	5.0	5.0	4.0
145	12.0	11.6	11.4	9.4	9.0	8.6	7.4	7.2	7.0	5.0	5.0	4.0
150	11.6	11.2	11.2	9.2	8.8	8.6	7.4	7.0	6.8	5.0	4.8	4.0
155	11.2	11.0	11.0	9.0	8.6	8.4	7.2	6.8	6.6	5.0	4.8	4.0
160	11.0	10.6	10.6	8.6	8.4	8.2	7.0	6.6	6.6	5.0	4.8	4.0
165	10.6	10.4	10.4	8.4	8.2	8.0	6.8	6.6	6.4	4.8	4.8	4.0
170	10.2	10.2	10.2	8.2	8.0	8.0	6.6	6.4	6.2	4.8	4.6	4.0
175	9.8	9.8	10.0	8.0	7.8	7.8	6.4	6.2	6.2	4.8	4.6	4.0
180	9.6	9.6	9.6	7.8	7.6	7.6	6.2	6.0	6.0	4.6	4.6	4.0
185	9.2	9.2	9.4	7.6	7.4	7.4	6.0	5.8	5.8	4.6	4.4	4.0
190	8.8	8.8	9.0	7.4	7.2	7.2	5.8	5.6	5.8	4.4	4.4	4.0
195	8.2	8.4	8.6	7.2	7.0	7.0	5.6	5.6	5.6	4.2	4.2	4.0
200	8.0	8.0		7.0	6.8	6.8	5.4	5.4	5.4	4.2	4.0	4.0
205	7.6	7.8		6.8	6.6	6.8	5.2	5.2	5.4	4.0	4.0	4.0
210	7.2	7.4		6.6	6.4	6.6	5.0	5.0	5.2	3.8	3.8	4.0
215	6.8	7.0		6.4	6.4	6.4	5.0	5.0	5.0	3.6	3.8	3.8
220	6.4	6.6		6.2	6.2	6.4	4.8	4.8	5.0	3.6	3.6	3.8
225	6.2	6.2		6.0	6.0	6.2	4.6	4.6	4.8	3.4	3.4	3.6
230	5.8	6.0		5.8	6.0		4.6	4.6	4.6	3.2	3.4	3.6
235	5.4	5.6		5.6	5.8		4.4	4.4	4.6	3.2	3.2	3.4
240				5.2	5.6		4.2	4.2	4.4	3.0	3.2	3.2
245				5.0	5.2		4.2	4.2	4.2	3.0	3.0	3.2
250				4.8	5.0		4.0	4.0		2.8	2.8	3.0
255				4.4	4.6		3.8	4.0		2.8	2.8	3.0
260				4.2	4.4		3.8	3.8		2.6	2.6	2.8
265				4.0	4.0		3.6	3.6		2.6	2.6	2.8
270				3.2			3.4	3.6		2.4	2.4	
275							3.2	3.4		2.4	2.4	
280							3.0	3.0		2.2	2.2	
285							2.6	2.6		2.2	2.2	
290							2.2	2.2		2.0	2.2	
295										2.0	2.0	

THIS CHART IS ONLY A GUIDE AND SHOULD NOT BE USED TO OPERATE THE CRANE.
The individual crane's load chart, operating instructions and other instructional plates must be read and understood prior to operating the crane.

Load charts Hydraulic offsettable swingaway

Intermediate angle and loads for luffing



Pounds x 1000

Radius	223' + 39.4'			223' + 68.9'			223' + 95.1'			223' + 121.4'		
	5°	5° - 20°	20° - 40°	5°	5° - 20°	20° - 40°	5°	5° - 20°	20° - 40°	5°	5° - 20°	20° - 40°
45	16.4											
50	16.4	16.4		10.0								
55	16.4	16.4		10.0			7.4					
60	16.4	16.4	16.4	10.0			7.4			5.0		
65	16.4	16.4	16.4	10.0			7.4			5.0		
70	16.4	16.4	16.4	10.0	10.0		7.4			5.0		
75	16.4	16.4	16.4	10.0	10.0		7.4	7.4		5.0		
80	16.4	16.4	16.4	10.0	10.0		7.4	7.4		5.0	5.0	
85	16.4	16.4	16.0	10.0	10.0		7.4	7.4		5.0	5.0	
90	16.4	16.2	15.6	10.0	10.0	9.4	7.4	7.4		5.0	5.0	
95	16.4	15.8	15.2	10.0	10.0	9.4	7.4	7.4	7.2	5.0	5.0	4.0
100	16.0	15.2	14.8	10.0	10.0	9.2	7.4	7.4	7.2	5.0	5.0	4.0
105	15.6	14.8	14.4	10.0	10.0	9.2	7.4	7.4	7.2	5.0	5.0	4.0
110	15.0	14.4	14.0	10.0	10.0	9.2	7.4	7.4	7.2	5.0	5.0	4.0
115	14.4	13.8	13.6	10.0	10.0	9.0	7.4	7.4	7.2	5.0	5.0	4.0
120	14.0	13.4	13.2	10.0	10.0	9.0	7.4	7.4	7.2	5.0	5.0	4.0
125	13.6	13.0	12.8	10.0	10.0	9.0	7.4	7.4	7.2	5.0	5.0	4.0
130	13.2	12.6	12.4	10.0	9.8	8.8	7.4	7.4	7.2	5.0	5.0	4.0
135	12.8	12.2	12.2	10.0	9.6	8.8	7.4	7.4	7.2	5.0	5.0	4.0
140	12.4	12.0	11.8	9.8	9.4	8.8	7.4	7.2	7.0	5.0	5.0	4.0
145	12.0	11.6	11.4	9.4	9.0	8.6	7.4	7.2	7.0	5.0	5.0	4.0
150	11.2	11.2	11.2	9.2	8.8	8.6	7.4	7.0	6.8	5.0	4.8	4.0
155	10.2	10.2	10.8	9.0	8.6	8.4	7.2	6.8	6.6	5.0	4.8	4.0
160	9.4	9.4	10.0	8.6	8.4	8.2	7.0	6.6	6.6	5.0	4.8	4.0
165	8.6	8.6	9.2	8.4	8.2	8.0	6.8	6.6	6.4	4.8	4.8	4.0
170	7.8	7.8	8.4	8.2	8.0	8.0	6.6	6.4	6.2	4.8	4.6	4.0
175	7.0	7.0	7.6	8.0	7.8	7.8	6.4	6.2	6.2	4.8	4.6	4.0
180	6.4	6.4	6.8	7.2	7.2	7.6	6.2	6.0	6.0	4.6	4.6	4.0
185	5.6	5.6	6.0	6.6	6.6	7.4	6.0	5.8	5.8	4.6	4.4	4.0
190	5.0	5.0	5.4	6.0	6.0	6.8	5.8	5.6	5.8	4.4	4.4	4.0
195	4.4	4.4		5.4	5.4	6.2	5.4	5.4	5.6	4.2	4.2	4.0
200	3.8	3.8	4.8	4.8	4.8	5.6	4.8	4.8	5.4	4.2	4.0	4.0
205	3.2	3.2		4.4	4.4	5.0	4.2	4.2	5.0	4.0	4.0	4.0
210	2.6	2.6		3.8	3.8	4.4	3.8	3.8	4.4	3.6	3.6	4.0
215	2.2	2.2		3.2	3.2	3.8	3.2	3.2	4.0	3.2	3.2	3.8
220				2.8	2.8	3.4	2.8	2.8	3.4	2.6	2.6	3.4
225				2.2	2.2	2.8	2.4	2.4	3.0	2.2	2.2	3.0
230							2.0	2.0		2.6	2.4	2.4
235										2.2		2.0

THIS CHART IS ONLY A GUIDE AND SHOULD NOT BE USED TO OPERATE THE CRANE.

Grove GMK5275 The individual crane's load chart, operating instructions and other instructional plates must be read and understood prior to operating the crane.

Load charts

Hydraulic offsettable swingaway

Intermediate angle and loads for luffing

 68 m
(223 ft)

 12-21-29-37 m
(39-69-95-121 ft)

 41 000 kg
(90,300 lb)

 26 ft 7 in spread
(100%)

 360°



Pounds (thousands)

Radius	223' + 39.4'		223' + 68.9'			223' + 95.1'			223' + 121.4'			
	5°	5° - 20°	20° - 40°	5°	5° - 20°	20° - 40°	5°	5° - 20°	20° - 40°	5°	5° - 20°	20° - 40°
	X 1000 lb											
45	16.4											
50	16.4	16.4		10.0								
55	16.4	16.4		10.0			7.4					
60	16.4	16.4	16.4	10.0			7.4			5.0		
65	16.4	16.4	16.4	10.0			7.4			5.0		
70	16.4	16.4	16.4	10.0	10.0		7.4			5.0		
75	16.4	16.4	16.4	10.0	10.0		7.4	7.4		5.0		
80	16.4	16.4	16.4	10.0	10.0		7.4	7.4		5.0	5.0	
85	16.4	16.4	16.0	10.0	10.0		7.4	7.4		5.0	5.0	
90	16.4	16.2	15.6	10.0	10.0	9.4	7.4	7.4		5.0	5.0	
95	16.4	15.8	15.2	10.0	10.0	9.4	7.4	7.4	7.2	5.0	5.0	4.0
100	16.0	15.2	14.8	10.0	10.0	9.2	7.4	7.4	7.2	5.0	5.0	4.0
105	15.6	14.8	14.4	10.0	10.0	9.2	7.4	7.4	7.2	5.0	5.0	4.0
110	15.0	14.4	14.0	10.0	10.0	9.2	7.4	7.4	7.2	5.0	5.0	4.0
115	14.4	13.8	13.6	10.0	10.0	9.0	7.4	7.4	7.2	5.0	5.0	4.0
120	13.8	13.4	13.2	10.0	10.0	9.0	7.4	7.4	7.2	5.0	5.0	4.0
125	12.6	12.6	12.8	10.0	10.0	9.0	7.4	7.4	7.2	5.0	5.0	4.0
130	11.6	11.6	12.4	10.0	9.8	8.8	7.4	7.4	7.2	5.0	5.0	4.0
135	10.4	10.4	11.2	10.0	9.6	8.8	7.4	7.4	7.2	5.0	5.0	4.0
140	9.4	9.4	10.2	9.8	9.4	8.8	7.4	7.2	7.0	5.0	5.0	4.0
145	8.6	8.6	9.2	9.4	9.0	8.6	7.4	7.2	7.0	5.0	5.0	4.0
150	7.6	7.6	8.4	8.6	8.6	8.6	7.4	7.0	6.8	5.0	4.8	4.0
155	6.8	6.8	7.4	7.8	7.8	8.4	7.2	6.8	6.6	5.0	4.8	4.0
160	6.0	6.0	6.6	7.0	7.0	8.2	6.8	6.6	6.6	5.0	4.8	4.0
165	5.4	5.4	6.0	6.2	6.2	7.4	6.2	6.2	6.4	4.8	4.8	4.0
170	4.8	4.8	5.2	5.6	5.6	6.6	5.4	5.4	6.2	4.8	4.6	4.0
175	4.0	4.0	4.6	5.0	5.0	6.0	4.8	4.8	6.0	4.6	4.6	4.0
180	3.4	3.4	4.0	4.4	4.4	5.4	4.2	4.2	5.2	4.0	4.0	4.0
185	2.8	2.8	3.4	3.8	3.8	4.6	3.6	3.6	4.6	3.6	3.6	4.0
190	2.4	2.4	2.8	3.2	3.2	4.0	3.2	3.2	4.0	3.0	3.0	4.0
195			2.2	2.8	2.8	3.6	2.6	2.6	3.6	2.6	2.6	3.4
200				2.2	2.2	3.0	2.2	2.2	3.0	2.0	2.0	2.8
205						2.4			2.4			2.4
210						2.0			2.0			2.0

Load charts

Heavy duty jib

Fixed angle

13,3 m-68 m
(44 ft-223 ft)

2,3 m
(7.5 ft)

77 000 kg
(169,700 lb)

26 ft 7 in spread
(100%)

360°



Pounds (thousands)

Radius	43.7' + 7.5'		74.3' + 7.5'		104.2' + 7.5'		133.4' + 7.5'		164.0' + 7.5'		193.9' + 7.5'		223.1' + 7.5'	
	8°	30°	8°	30°	8°	30°	8°	30°	8°	30°	8°	30°	8°	30°
10.0		83.0		83.0										
15.0		83.0		83.0										
20.0		83.0		83.0		83.0		83.0						
25.0		83.0		83.0		83.0		83.0						
30.0	83.0	83.0		83.0		83.0		81.0						
35.0	83.0	83.0		83.0		83.0		77.0		58.0				
40.0				83.0		83.0		73.0		58.0		37.0		
45.0				83.0		83.0		69.0		58.0		37.0		25.4
50.0			83.0	83.0		83.0		65.0		58.0		37.0		25.4
55.0			83.0	83.0		83.0		62.0		55.0		37.0		25.4
60.0			74.0			78.0		59.0		52.0		37.0		25.4
65.0			60.0			71.0		57.0		49.0		37.0		25.4
70.0						65.0		54.0		45.0		36.6		25.4
75.0						59.0	59.0	52.0		42.2		34.8		25.4
80.0						54.0	54.0	50.0		38.8		33.0		25.4
85.0						51.0	51.0	47.0		36.2		31.2		25.4
90.0						45.0	47.0	46.0		34.0		29.8		25.4
95.0								44.0	43.4	31.8		28.2		24.6
100.0								40.6	40.8	29.6		26.6		23.8
105.0								37.4	37.6	27.8		24.8		22.4
110.0								34.4	34.6	26.2		23.0		21.0
115.0								31.8	32.0	24.6		21.2		19.6
120.0								28.2		22.6		20.0		18.8
125.0										20.6		18.8		17.8
130.0										19.4		17.8		17.0
135.0										18.4		16.8		16.2
140.0										17.4		15.8		15.4
145.0												15.0		14.6
150.0												14.0		14.0
155.0												13.4		13.4
160.0												12.6		12.8
165.0												11.8		12.2
170.0												11.2		11.6
175.0														11.0
180.0														10.4
185.0														10.0
190.0														9.4

Load charts Heavy duty jib

























Fixed angle

13.3 m-68 m (44 ft-223 ft)
 2,3 m (7.5 ft)
 51 000 kg (112,400 lb)
 26 ft 7 in spread (100%)
 360°

Pounds (thousands)

Radius	43.7' + 7.5'		74.3' + 7.5'		104.2' + 7.5'		133.4' + 7.5'		164.0' + 7.5'		193.9' + 7.5'		223.1' + 7.5'	
	8°	30°	8°	30°	8°	30°	8°	30°	8°	30°	8°	30°	8°	30°
10.0		83.0		83.0										
15.0		83.0		83.0										
20.0		83.0		83.0										
25.0		83.0		83.0										
30.0	83.0	83.0		83.0				81.0						
35.0	83.0	83.0		83.0				77.0						
40.0				83.0				73.0				37.0		
45.0				83.0				69.0				37.0		25.4
50.0			78.0	79.0				65.0				37.0		25.4
55.0			67.0	68.0				62.0				37.0		25.4
60.0			57.0					59.0				37.0		25.4
65.0			52.0					54.0				37.0		25.4
70.0								51.0				36.6		25.4
75.0					45.0	45.0		43.6				34.8		25.4
80.0					40.0	40.6		39.6				33.0		25.4
85.0					36.0	36.4		36.2				31.2		25.4
90.0					32.4	32.8		32.8				28.8		25.4
95.0							29.2	29.6				26.2		24.6
100.0							26.4	26.8				23.8		23.8
105.0							24.0	24.2				21.8		22.4
110.0							22.2	22.0				19.8		20.8
115.0							20.8	20.4				17.8		19.2
120.0							20.0					16.0		17.6
125.0												14.4		16.2
130.0												12.8		14.8
135.0												12.0		13.6
140.0												11.4		12.6
145.0														11.4
150.0														10.4
155.0														9.4
160.0														8.4
165.0														7.6
170.0														6.8
175.0														6.0
180.0														5.2
185.0														4.4
190.0														3.8

Symbols glossary

 Axles	 Counterweight	 Grade	 Gear
 Boom	 Drive	 Heavy duty jib	 Radius
 Boom elevation	 Electrical system	 Hoist	 Rotation
 Boom extension	 Engine	 Hookblock	 Speed
 Boom length	 Extension	 Hydraulic system	 Steering
 Boom nose	 Frame	 Lights	 Suspension
 Brakes	 Fuel tank capacity	 Oil	 Swing
 Cab	 Outriggers	 Outrigger controls	 Tires
			 Transmission

Notes



Regional headquarters

Manitowoc - Americas

Manitowoc, Wisconsin, USA
Tel: +1 920 684 6621
Fax: +1 920 683 6277

Shady Grove, Pennsylvania, USA
Tel: +1 717 597 8121
Fax: +1 717 597 4062

Manitowoc - Europe, Middle East & Africa

Ecully, France
Tel: +33 (0)4 72 18 20 20
Fax: +33 (0)4 72 18 20 00

Manitowoc - Asia Pacific

Shanghai, China
Tel: +86 21 6457 0066
Fax: +86 21 6457 4955

Regional offices

Americas

Brazil
Alphaville
Mexico
Monterrey
Chile
Santiago

Europe, Middle East & Africa

Czech Republic
Netvorice
France
Baudemont
Cergy
Decines
Germany
Langenfeld
Hungary
Budapest
Italy
Parabiago
Netherlands
Breda
Poland
Warsaw

Portugal

Baltar
Russia
Moscow
U.A.E.
Dubai
U.K.
Gawcott

Asia - Pacific

Australia
Brisbane
Melbourne
Sydney
China
Beijing
Xi'an
India
Hyderabad
Pune
Korea
Seoul
Philippines
Makati City
Singapore

Factories

Brazil
Alphaville
China
TaiAn
Zhangjiagang
France
Charlieu
La Clayette
Moulines
Germany
Wilhelmshaven
India
Pune
Italy
Niella Tanaro
Portugal
Baltar
Fânzeres
Slovakia
Saris
USA
Manitowoc
Port Washington
Shady Grove

This document is non-contractual. Constant improvement and engineering progress make it necessary that we reserve the right to make specification, equipment, and price changes without notice. Illustrations shown may include optional equipment and accessories and may not include all standard equipment.