



## ATF160G-5

200 Ton Capacity (181.4 Metric Tons)

### ALL TERRAIN CRANE

#### DIMENSIONS

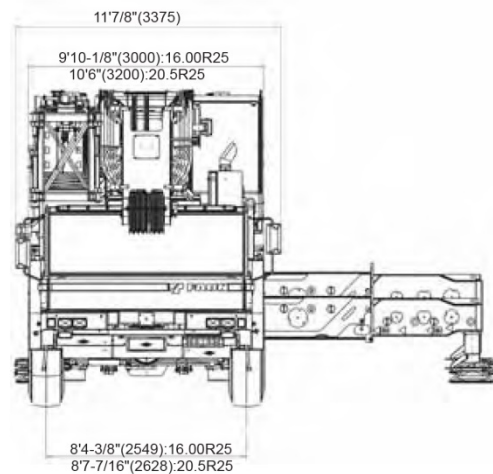
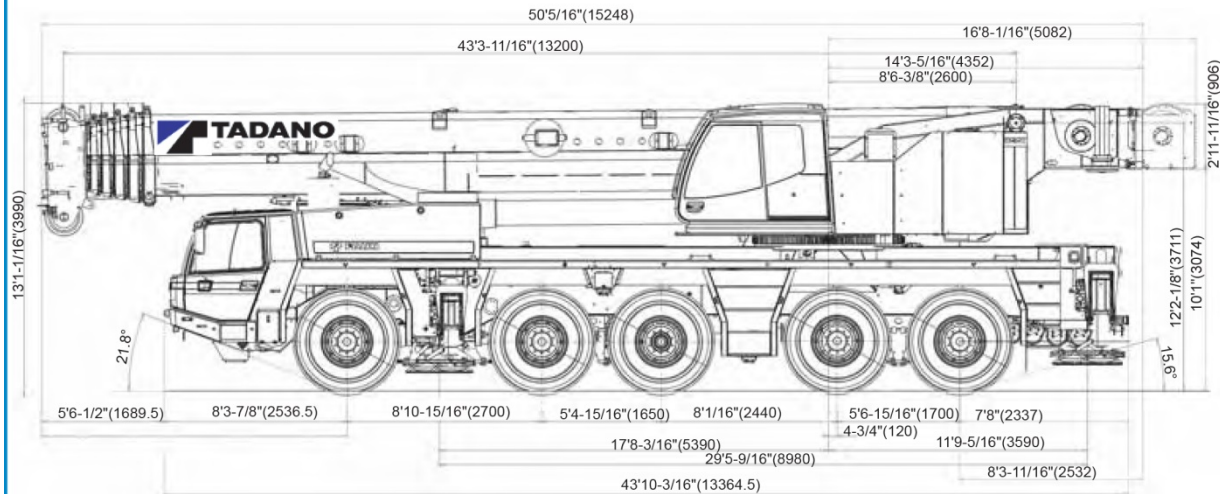

#### TURNING RADIUS

Steering	Front wheel (10x4)	All wheel (10x8)
Carrier inside	21' 11-3/4" (6.7m)	17' 4-11/16" (5.3m)
Over carrier	40' 8-3/16" (12.4m)	35' 9-1/8" (10.9m)
Over boom	42' 7-13/16" (13.0m)	38' 11/16" (11.6m)
Over boom extension	45' 1-5/16" (13.75m)	40' 4-1/4" (12.3m)

Specifications are subject to change without notice.

## 1. CRANE CARRIER

### 1.1 FRAME

FAUN purpose built, 5 axle, box-type, torsion resistant, welded construction made of high tensile steel with integrated outrigger housings. Equipped with front and rear fenders, front and rear towing and tie-down lugs and towing connections and access ladders. Central lubrication system.

### 1.2 OUTRIGGERS

Four point, fully hydraulic, double telescopic outriggers with horizontal and vertical motions are independently controlled by electro-magnetic valves. Push button controls with level gauges on both sides of carrier and in super-structure cab. Vertical cylinders with integral holding valves. Large sized floats can be stored on vertical cylinders or on carrier for road travel. Outrigger base: length 27'2-3/4" (8.3m), width 29' 5-9/16" (8.98m) Mid. extension 18' 4-1/2" (5.6m). Outrigger floats 1'11-5/8" (600mm) x 1'11-5/8" (600mm)

### 1.3 CARRIER ENGINE

Mercedes Benz 8 cylinder water-cooled diesel engine, model OM 502 LA (EUROMOT2,EPA), with hydrostatically driven fan and thermostatically controlled cooler. Displacement 971.98 in<sup>3</sup>, Rating 517 hp at 1,800 rpm: Torque 1,770 ft-lbs at 1,200 rpm.

### 1.4 TRANSMISSION

ZF AS-Tronic, type 16AS2602, with integrated intarder. Electro-pneumatically controlled dry clutch and fully automatic control system, 16 forward speeds and 2 reverse gears. Gear ratios Forward: 14.12 / 11.68 / 9.54 / 7.89 / 6.52 / 5.39 / 4.57 / 3.78 / 3.09 / 2.56 / 2.09 / 1.73 / 1.43 / 1.18 / 1.00 / 0.83 Reverse: 13.07 / 10.81

### 1.5 TRANSFER CASE

Two-step transfer box, type VG3750, with on/off road drive. Gear ratios On-road: 0.8 Off-road: 1.836

### 1.6 DRIVE

10x8 for on-road and off-road: 1st, 2nd, 4th and 5th axle are driven

### 1.7 AXLES

1st axle : steered, driven with transverse differential lock, reduction : 8.47  
2nd axle steered, driven with transverse differential lock, reduction : 8.47  
3rd axle : non steered, non driven, lift axle  
4th axle : steered, driven with longitudinal differential lock and transverse differential lock, reduction : 8.47  
5th axle : steered, driven with transverse differential lock, reduction : 8.47  
All steering knuckle bearings designed for minimum maintenance (yearly inspection).

### 1.8 SUSPENSION

Hydro-pneumatic, lockable with level adjustment. All axles have longitudinal and transverse trailing arms. With leveling adjustment and locked cylinders, the chassis can be tilted laterally and longitudinally by push buttons in the carrier cab, or from the control panel of the outrigger which adjust the stroke of each individual suspension cylinder.

Cylinder stroke: - 4-5/8" (- 118mm)  
+6-3/16" (+ 157mm)

### 1.9 BRAKE SYSTEM

Service brake : Dual circuit compressed air system with air-dryer. ABS(OPTIONAL)  
Parking brake : Spring loaded type, acting on 2nd,4th and 5th axles.  
Auxiliary brake : Interder,engine exhaust brake and constant throttle engine brake system.

### 1.10 WHEELS AND TIRES

(10)11.00-25 steel disc wheels with (10)16.00R25 on / off-road profile tires and mud flaps.  
Carrier width: 9'10-1/8" (3.0m) with 16.00R25 tires  
10' 6" (3.2m) with 20.5R25 tires (OPTIONAL)

### 1.11 STEERING SYSTEM

ZF semi block dual circuit hydraulic steering, Mechanical steering of two front axles with hydraulic booster and a emergency steering pump is flange-mounted to the transfer box.  
Rear axles can also be steered electronically depends on the speed according to the steering angle of the front axles. Rear axles are locked in "centered" position automatically.

### 1.12 POWER TRAIN

Drive-shafts with cross-geared flanges virtually maintenance-free.

### 1.13 FUEL TANK CAPACITY

140 gal (530 l) filler cap lockable.

### 1.14 CARRIER CAB

Two man full width cab of composite structure (steel sheet metal and fiber glass), windshield of laminated safety glass with windshield wiper and washer, sliding side windows of tempered glass. Driver and co-driver seats adjustable and air-suspended with integrated 3 point safety belts and headrests. 2 rear-view mirrors (electrically adjustable), 1 wide angle mirror and additional curb mirror, all mirrors heated, Radio with CD player and connections for wireless. Engine dependent warm-water heater with defroster nozzles for windshield and cab floor. Cruise control function. Single-key system. Instrumentation includes speedometer, odometer, tachograph, rpm counter with hour meter, fuel level gauge, warning light for the engine temperature, gearbox display, colour display indicating further warning signals and operating functions and the compressed air system. Air conditioner(OPTIONAL)

### 1.15 ELECTRICAL SYSTEM

24 volt DC system with 100 ampere 3-phase generator, and two 12 volt, 170 Ah batteries.  
Front lighting includes 2 main head lights, 2 high beam lights, 2 directional indicators and 2 parking lights.  
Rear lighting includes 2 rear combi panels each with directional indicator, parking light, brake light, fog light, reversing light and license plate light.  
Side lighting includes 2 front directional indicators and reflectors on carrier.  
Other equipment includes hazard warning light system, cab light, instrument panel light, signal horn and amber rotating beacon on cab roof.  
Charging plugbox. Back up alarm. 2 front fog lights.  
4 lights to illuminate the area of the extended outriggers. Lighting according to EEC regulations.

## 1.16 TOOLS AND ACCESSORIES

Special tool set, hazard warning triangle, hazard falshing lamp, fire extinguisher and first aid kit.

## 1.17 PAINTING

Standard TADANO colors

## 1.18 DIMENSIONS

Overall width : 9'10-1/8" (3.0m) with 16.00R25 tires  
10' 6" (3.2m) with 20.5R25 tires  
Overall height : 13' 1-1/16" (3.99m)  
In travel condition, the overall height can be adjusted - 4-5/8" / + 6-3/16"  
Overall length : 50' 5/16" (15.248m)  
52' 5-1/16" (15.978m) with Aux. winch  
Carrier length : 43' 10-3/16" (13.3645m)  
Wheel base : 8' 10-15/16" + 5' 4-15/16" + 8' 1/16" + 5' 6-15/16"  
(2.7m + 1.65m + 2.44m + 1.7m )

## 1.19 CARRIER OPTIONAL EQUIPMENT

1. Air conditioning
2. 20.5R25 on/off road profile tires
3. Spare weel & tire
4. ABS
5. Eddy current brake (retarder)
6. Rear view camara(image in display in carrier cab)
7. Spark arrester
8. Toolbox rear
9. Towing attachment(D-Value 190 kN)
10. Pneumatic and electrical quick disconnect connectors mounted on rear bumper for boom dolly

## 2. TRAVEL PERFORMANCE (according to DIN 70020)

Max. travel speed : 52.8 mph

Max. gradeability : 61 %

Gear	16.00R25 / 20.5R25 tires, GVW 132,275 lb			
	Travelling speed (mph)		Gradabilities (%)	
	Off-road gear	On -road gear	Off-road gear	On -road gear
1st	1.9	3.7	61	47
2nd	1.9	4.3	47	39
3rd	2.5	5.0	37	31
4th	2.5	6.2	30	25
5th	3.1	7.5	24	20
6th	4.3	9.3	19	16
7th	5.0	11.2	16	14
8th	5.6	13.0	13	11
9th	6.8	16.2	11	9
10th	8.7	19.3	8	7
11th	10.6	23.6	7	6
12th	12.4	28.6	5	4
13th	14.9	34.8	4	3
14th	19.6	42.3	3	3
15th	21.7	49.7	3	2
16th	26.1	52.8	2	1
1st Rev.	1.9	3.7	55	45
2nd Rev.	1.9	4.3	43	36

The gradeability is based on theoretical values and depends on ground conditions and the coefficient of friction.  
A minimum speed of 0.6 MPH is in 1st gear(off-road) at 800 rpm.

## 3. SUPERSTRUCTURE

### 3.1 SUPERSTRUCTURE FRAME

Connected to carrier by a single-race ball bearing slewing ring with external gearing providing 360° continuous rotation. Central lubrication system for slewing device, boom elevation cylinder and basic bearing.

### 3.2 CRANE ENGINE

Mercedes Benz 6 cylinder water-cooled diesel engine, model OM 906 LA(EUROMOT 2,EPA), with 184 hp at 1,800 rpm, 553.17 ft-lbs torque at 1,200 - 1,600 rpm. Stepless control of engine rpm by foot pedal.  
Fuel tank capacity : 66.04 gal (250 l)

### 3.3 HYDRAULIC SYSTEM

Three circuit diesel hydraulic system with 1 axial piston variable displacement (hydraulically controlled) double pump with cumulative control for telescoping, derricking and hoisting plus 1 axial piston pump for swing and pilot controls.

### 3.4 HYDRAULIC CONTROLS

2 joy-stick levers and 4 three-way electrically operated valves for independent simultaneous operation of all crane motions with stepless speed control.

### 3.5 TELESCOPIC BOOM

Six section box type construction of high tensile, fine grained steel, consisting of 1 base section and 5 telescopic sections. The boom is extended by means of 1 double acting single stage cylinders with integrated holding valves.

All telescope sections can be extended and retracted fully automatic and locked in the selected working position.

All telescope sections are extendable under partial load.

Total retracted length : 43' 3-11/16" (13.2m)

Total extended length : 196' 10-3/16" (60.0m)

Max. sheave height : 203' 4-15/16" (62.0m)

Telescoping speed out : 400 sec.

### 3.6 BOOM EXTENSION

Swing around lattice type boom extension 17.72'(5.4m) / 43.31'(13.2m), offsets 0°/ 20°/ 40°with anti-two block system.

4 intermediate sections(19.69' each) to extend to 122.05'(37.2m).

### 3.7 AUXILIARY LIFTING SHEAVE (SINGLE TOP) (OPTIONAL)

Single sheave mounted to main boom head for single line operation (stowable). Equipped with anti-two block system .

### 3.8 BOOM HOIST

1 double acting hydraulic cylinder with integral holding valve.

Boom elevation : -1.5° to +84°

Boom elevation speed : 100 sec. normal speed /  
50 sec. high speed (only derricking up)

### 3.9 MAIN WINCH

Axial piston constant displacement motor, grooved hoist drum, integral planetary gear, automatic hydraulically controlled spring-loaded multiple disc brake and integral free wheeling (no sagging of load by hoisting).

Winch drive assembly connected to open hydraulic system. Wire rope with "Superstop" easy reeving system.

Lower limit switch and drum turn indicator.

Drum diameter : 20.67" (525mm)

Rope diameter : 0.83" (21mm)

Rope length : 1,107' (310m)

Max. line pull 3rd layer : 21,356 lbs. (95 kN)

Max. line speed 4th layer : 426.5 ft/min (130m/min)

### 3.10 AUXILIARY WINCH (OPTIONAL)

Axial piston constant displacement motor, grooved hoist drum, integral planetary gear, automatic hydraulically controlled spring-loaded multiple disc brake and integral free wheeling (no sagging of load by hoisting).

Winch drive assembly connected to open hydraulic system. Wire rope with "Superstop" easy reeving system. Lower limit switch and drum turn indicator.

Drum diameter : 20.67" (525mm)

Rope diameter : 0.83" (21mm)

Rope length : 1,107' (310m)

Max. line pull 3rd layer : 21,356 lbs. (95 kN)

Max. line speed 4th layer : 426.5 ft/min (130m/min)

### 3.11 SLEWING GEAR

Constant displacement motor with three stage planetary gear, a foot actuated or automatic service brake and a parking brake. Open hydraulic circuit with free slewing function. Slewing speed infinitely variable: 0 - 1.5 rpm

### 3.12 COUNTERWEIGHT

Total 112,435 lbs, divisible, assembled and disassembled by hydraulic cylinders controlled from crane cab.

Tail swing : 15' 11-1/8" (4.855m)

16' 8-1/16" (5.082m) with Aux. winch

### 3.13 SUPERSTRUCTURE CAB

Spacious comfortable panoramic cab with sliding door, extra-large tinted glass windows, electrical fold-out front window with windshield washer and wiper, fixed cab roof window with armoured glass and washer/wiper, sun visor, cab light, tiltable cockpit with adjustable hydraulically cushioned seat with headrest, signal horn, radio with CD player, and connection for wireless (12 volt).

Engine dependent hot-water heater and engine independent hot water heater with engine pre-heat.

Complete controls and instrumentation plus LCD graphic display for crane operation.

Outtrigger controls from superstructure cab and supported forces display.(OPTIONAL)

Air conditioner.(OPTIONAL)

### 3.14 ELECTRICAL SYSTEM

24 volt system with 30 A 3-phase alternator, two 12 V (110 Ah) batteries, 1 rotating beacon on right-hand side of main winch, 2 working lights on cab front flap, 1 working light on boom base section and 2 side lights on boom head.

### 3.15 SAFETY DEVICES

Electronic load moment device (AML) with interpolation and automatic overload shut-off, hoist limit switch with shut-off, overload warning and load moment gauge. Anemometer. Digital display of boom angle, boom length, sheave height, working radius, hook load and further information.

Working area limitation for lifting height, load radius, boom angle and swing range.

"Lift Adjuster" function, enables the load to be lifted without swinging (automatic derricking up, which keeps the working radius constant.)

Safety valves against pipe and hose rupture, holding valves on hydraulic cylinders.

### 3.16 SUPERSTRUCTURE OPTIONAL EQUIPMENT

1. Air conditioning
2. 11 ton headache ball
3. 27.5 ton, 1 sheave single hook block
4. 69.4 ton, 3 sheave ram's horn hook block
5. 88.0 ton, 5 sheave ram's horn hook block
6. 138.0 ton, 7 sheave ram's horn hook block
7. 176.5 ton, 9 sheave ram's horn hook block
8. 200.0 ton, 11 sheave ram's horn hook block
9. Additional pulleys for lifting loads of more than 121 ton
10. Auxiliary winch
11. Auxiliary lifting sheave
12. 19.69' intermediate sections for boom extension (1 to 4 sections)
13. Spark arrester
14. Aircraft warning lamp
15. Outtrigger load display with monitoring (in superstructure cab and in outtrigger control panels)
16. Additional Hydraulic oil cooler
17. Working area limitation(Slew limit)
18. Free slewing and free boom elevation circuits for boom dolly.
19. 360° positive swing lock (NYC requirement).

## ATF160G-5 WORKING RANGE CHART

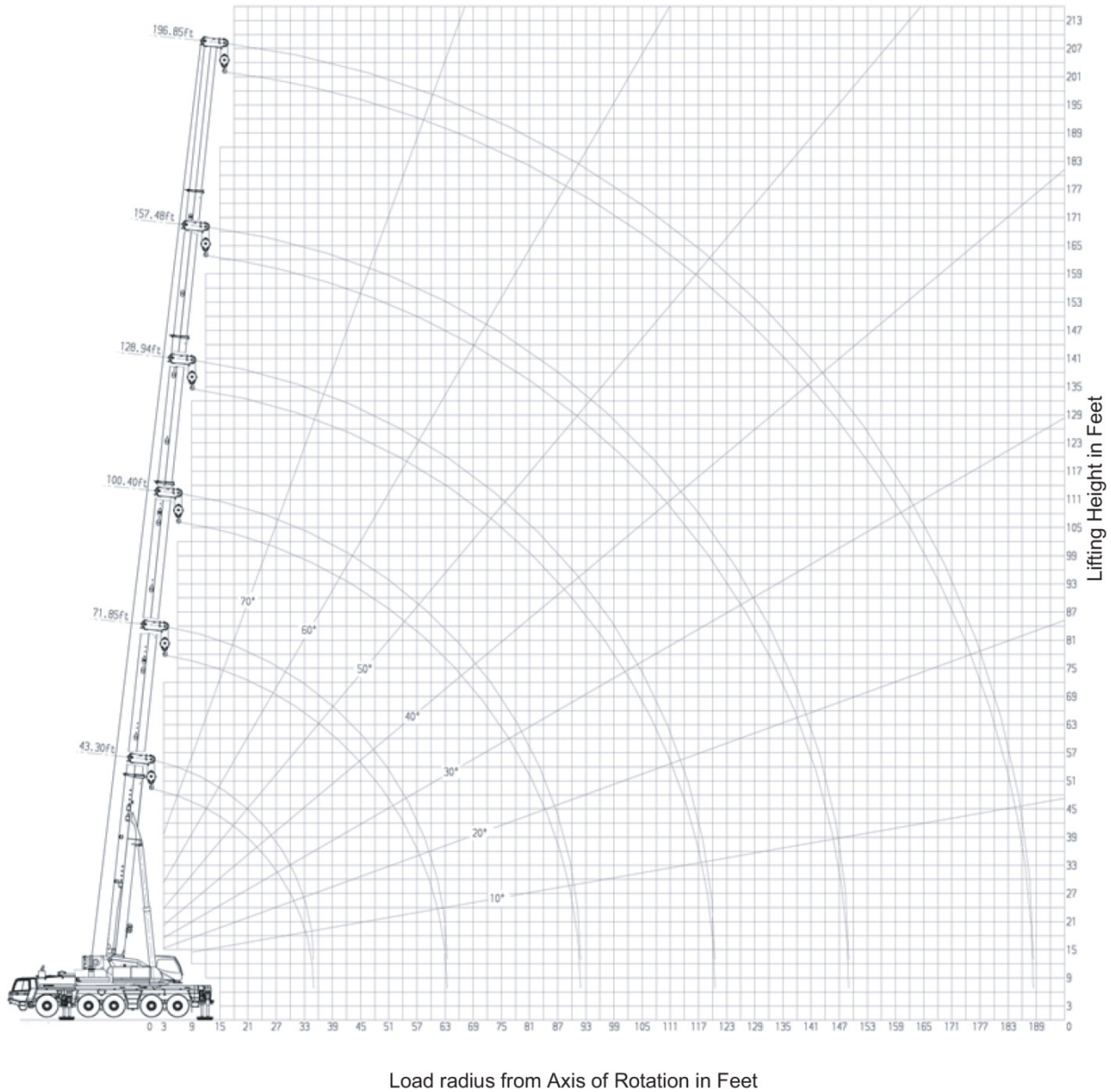

**NOTE:** Boom and jib geometry shown are for unloaded condition and machine standing level on firm supporting surface. Boom deflection and subsequent radius and boom angle change must be accounted for when applying load to hook.



### Counterweight 112,435 lbs

Work Radius (ft)	Lifting capacities in 1,000 lbs according per SAE J765 on telescopic boom On outriggers, 360° working area Outrigger base 27.23 ft														Work Radius (ft)					
	Boom length (ft)																			
	128.9	128.9	128.9	143.4	143.4	143.3	157.5	157.5	157.5	171.9	171.9	186.0	196.9							
9																	9			
10																	10			
12																	12			
14																	14			
16																	16			
18																	18			
20	81	57.2	81	91.3	81	71.0	82	49.4	82	54.0	82	73.6					20			
25	78	51.6	78	91.3	78	68.0	80	49.4	80	53.7	80	73.6	81	43.0	81	59.3	81	49.2	25	
30	76	45.9	76	83.8	76	61.9	78	47.2	78	50.1	78	73.3	80	43.0	80	59.3	80	49.2	30	
35	74	41.4	74	75.3	74	56.8	76	42.8	76	45.9	76	68.3	78	42.0	78	58.0	78	48.1	35	
40	72	37.5	72	68.0	72	52.4	74	39.1	74	42.2	74	61.7	76	39.5	76	54.9	76	45.9	40	
45	69	34.1	69	62.0	69	48.6	71	36.1	71	39.1	71	56.5	74	36.7	74	51.2	74	42.7	45	
50	66	31.3	66	56.7	66	45.4	69	33.3	69	36.5	69	51.9	72	34.1	72	47.9	72	39.8	50	
55	64	28.9	64	52.2	64	42.5	67	30.9	67	34.2	67	47.8	70	31.8	70	44.6	70	37.2	55	
60	61	26.8	61	48.3	61	39.9	65	28.8	65	32.1	65	44.2	68	29.9	68	41.3	68	34.9	60	
65	58	24.9	58	44.7	58	37.7	62	26.9	62	30.2	62	41.0	66	28.0	66	38.5	66	32.9	65	
70	56	23.4	56	41.8	56	35.9	60	25.2	60	28.5	60	38.2	64	26.5	64	35.9	64	31.2	70	
75	53	21.9	53	40.4	53	34.1	58	23.7	58	27.0	58	35.7	62	24.9	62	33.6	62	29.6	75	
80	50	20.4	50	39.2	50	32.5	55	22.4	55	25.7	55	33.4	59	23.5	59	31.5	59	28.1	80	
85	47	19.3	47	35.5	47	31.0	53	21.2	53	24.5	53	31.4	57	22.3	57	29.4	57	26.5	85	
90	43	18.2	43	32.3	43	29.6	50	20.1	50	23.4	50	30.0	55	21.3	55	27.7	55	25.4	90	
95	40	17.3	40	29.4	40	28.5	47	19.1	47	22.4	47	28.5	53	20.3	53	26.2	53	24.3	95	
100	36	16.5	36	26.8	36	27.5	44	18.3	44	21.6	44	26.6	50	19.4	50	24.8	50	23.3	100	
110	27	15.0	27	22.3	27	25.1	38	16.6	38	19.9	38	22.2	45	17.7	45	22.1	45	21.4	110	
120							29	15.2	29	18.5	29	18.5	39	16.3	39	19.0	39	19.9	120	
130							18	14.2	18	17.7	18	15.4	32	15.2	32	15.8	32	17.9	130	
140													23	13.8	23	13.4	23	15.4	140	
150																				150
160																				160
170																				170
180																				180
190																				190
Telescoping sequence %																				
Tel. 1	0	93	46	0	46	93	0	93	46	46	93	46	93	93	93	93	100	Tel. 1		
Tel. 2	0	46	46	46	46	93	93	93	93	93	93	93	93	93	93	93	100	Tel. 2		
Tel. 3	93	46	46	93	46	46	93	93	93	93	93	93	93	93	93	100	Tel. 3			
Tel. 4	93	46	46	93	93	46	93	46	93	93	93	93	93	93	93	100	Tel. 4			
Tel. 5	93	46	93	93	93	46	93	46	46	93	46	46	93	46	93	100	Tel. 5			

Operation and maintenance of this machine must be in compliance with the information provided in the "Operation and Maintenance Manual" supplied with this machine.

### Counterweight 81,570 lbs

Work Radius (ft)	Lifting capacities in 1,000 lbs according per SAE J765 on telescopic boom On outriggers, 360° working area Outrigger base 27.23 ft														Work Radius (ft)					
	Boom length (ft)																			
	128.9	128.9	128.9	143.4	143.4	143.3	157.5	157.5	157.5	171.9	171.9	186.0	196.9							
9																				9
10																				10
12																				12
14																				14
16																				16
18																				18
20	81	57.2	81	91.3	81	71.0	82	49.4	82	54.0	82	73.6							20	
25	78	51.6	78	91.3	78	68.0	80	49.4	80	53.7	80	73.6	81	43.0	81	59.3	81	49.2	25	
30	76	45.9	76	83.8	76	61.9	78	47.2	78	50.1	78	73.3	80	43.0	80	59.3	80	49.2	30	
35	74	41.4	74	75.3	74	56.8	76	42.8	76	45.9	76	68.3	78	42.0	78	58.0	78	48.1	35	
40	72	37.5	72	68.0	72	52.4	74	39.1	74	42.2	74	61.7	76	39.5	76	54.9	76	45.9	40	
45	69	34.1	69	62.0	69	48.6	71	36.1	71	39.1	71	56.5	74	36.7	74	51.2	74	42.7	45	
50	66	31.3	66	56.7	66	45.4	69	33.3	69	36.5	69	51.9	72	34.1	72	47.9	72	39.8	50	
55	64	28.9	64	52.2	64	42.5	67	30.9	67	34.2	67	47.8	70	31.8	70	44.6	70	37.2	55	
60	61	26.8	61	48.3	61	39.9	65	28.8	65	32.1	65	44.2	68	29.9	68	41.3	68	34.9	60	
65	58	24.9	58	44.7	58	37.7	62	26.9	62	30.2	62	41.0	66	28.0	66	38.5	66	32.9	65	
70	56	23.4	56	41.8	56	35.9	60	25.2	60	28.5	60	37.9	64	26.5	64	35.9	64	31.2	70	
75	53	21.9	53	34.3	53	34.1	58	23.7	58	27.0	58	34.3	62	24.9	62	33.6	62	29.6	75	
80	50	20.4	50	30.5	50	32.3	55	22.4	55	25.7	55	30.5	59	23.5	59	30.9	59	28.1	80	
85	47	19.3	47	27.3	47	29.9	53	21.2	53	24.5	53	27.1	57	22.3	57	27.8	57	26.5	85	
90	43	18.2	43	24.4	43	27.2	50	20.1	50	23.4	50	24.4	55	21.3	55	24.9	55	25.4	90	
95	40	17.3	40	21.8	40	24.8	47	19.1	47	22.4	47	21.8	53	20.3	53	22.3	53	23.9	95	
100	36	16.5	36	19.4	36	22.6	44	18.3	44	21.6	44	19.4	50	19.4	50	22.0	50	22.0	100	
110	27	15.0	27	15.6	27	18.9	38	16.6	38	19.4	38	15.5	45	17.7	45	16.0	45	18.2	110	
120							29	15.2	29	16.4	29	12.3	39	16.2	39	12.9	39	14.9	120	
130							18	14.2	18	13.7	18	9.8	32	14.4	32	10.3	32	12.4	130	
140													23	12.1	23	8.2	23	10.1	140	
150																				150
160																				160
170																				170
180																				180
190																				190
Telescoping sequence %																				
Tel. 1	0	93	46	0	46	93	0	93	46	46	93	46	93	46	93	93	100	Tel. 1		
Tel. 2	0	46	46	46	46	93	93	93	93	93	93	93	93	93	93	93	100	Tel. 2		
Tel. 3	93	46	46	93	46	46	93	93	93	93	93	93	93	93	93	93	100	Tel. 3		
Tel. 4	93	46	46	93	93	46	93	46	93	46	93	46	93	46	93	93	100	Tel. 4		
Tel. 5	93	46	93	93	93	46	93	46	46	93	46	46	93	46	93	46	93	100	Tel. 5	

Operation and maintenance of this machine must be in compliance with the information provided in the "Operation and Maintenance Manual" supplied with this machine.





### Counterweight 55,115 lbs

Work. Radius (ft)	Lifting capacities in 1,000 lbs according per SAE J765 on telescopic boom On outriggers, 360° working area Outrigger base 27.23 ft														Work. Radius (ft)
	Boom length (ft)														
	128.9	128.9	128.9	143.4	143.4	143.3	157.5	157.5	157.5	171.9	171.9	186.0	196.9		
9															9
10															10
12															12
14															14
16															16
18															18
20	81	57.2	81	91.3	81	71.0	82	49.4	82	54.0	82	73.6			20
25	78	51.6	78	91.3	78	68.0	80	49.4	80	53.7	80	73.6			25
30	76	45.9	76	83.8	76	61.9	78	47.2	78	50.1	78	73.3			30
35	74	41.4	74	75.3	74	56.8	76	42.8	76	45.9	76	68.3			35
40	72	37.5	72	67.8	72	52.4	74	39.1	74	42.2	74	61.7			40
45	69	34.1	69	59.7	69	48.6	71	36.1	71	39.1	71	56.5			45
50	66	31.3	66	51.8	66	45.4	69	33.3	69	36.5	69	49.4			50
55	64	28.9	64	44.7	64	42.4	67	30.9	67	34.2	67	42.8			55
60	61	26.8	61	38.7	61	39.5	65	28.8	65	32.1	65	37.3			60
65	58	24.9	58	33.3	58	36.1	62	26.9	62	30.2	62	33.1			65
70	56	23.4	56	29.1	56	32.2	60	25.2	60	28.5	60	28.9			70
75	53	21.9	53	25.3	53	28.5	58	23.7	58	26.7	58	25.1			75
80	50	20.4	50	22.0	50	25.3	55	22.4	55	24.8	55	21.8			80
85	47	19.3	47	19.3	47	22.4	53	21.2	53	22.8	53	19.1			85
90	43	18.2	43	17.0	43	20.1	50	20.1	50	20.8	50	16.7			90
95	40	17.3	40	14.8	40	17.9	47	18.8	47	14.7	53	18.9			95
100	36	16.4	36	12.9	36	16.0	44	17.5	44	16.8	44	12.9			100
110	27	14.3	27	9.7	27	12.8	38	15.0	38	13.5	38	9.5			110
120							29	12.4	29	11.0	29	6.8			120
130						18	10.2	18	8.8	18	4.8	3.2			130
140												2.3			140
150															150
160															160
Telescoping sequence %															
Tel. 1	0	93	46	0	46	93	0	93	46	46	93	93	100	Tel. 1	
Tel. 2	0	46	46	46	46	93	93	93	93	93	93	93	100	Tel. 2	
Tel. 3	93	46	46	93	46	46	93	93	93	93	93	93	100	Tel. 3	
Tel. 4	93	46	46	93	93	46	46	93	46	93	93	93	100	Tel. 4	
Tel. 5	93	46	93	93	93	46	46	93	46	46	93	46	93	Tel. 5	

Operation and maintenance of this machine must be in compliance with the information provided in the "Operation and Maintenance Manual" supplied with this machine.

### Counterweight 28,660 lbs

Work. Radius (ft)	Lifting capacities in 1,000 lbs according per SAE J765 on telescopic boom On outriggers, 360° working area Outrigger base 27.23 ft														Work. Radius (ft)
	Boom length (ft)														
	128.9	128.9	128.9	143.4	143.4	143.3	157.5	157.5	157.5	171.9	171.9	186.0	196.9		
9															9
10															10
12															12
14															14
16															16
18															18
20	81	57.2	81	91.3	81	71.0	82	49.4	82	54.0	82	73.6			20
25	78	51.6	78	91.3	78	68.0	80	49.4	80	53.7	80	73.6			25
30	76	45.9	76	83.8	76	61.9	78	47.2	78	50.1	78	73.3			30
35	74	41.4	74	70.6	74	56.8	76	42.8	76	45.9	76	68.0			35
40	72	37.5	72	55.6	72	52.2	74	39.1	74	42.2	74	55.3			40
45	69	34.1	69	46.8	69	46.9	71	36.1	71	39.1	71	46.6			45
50	66	31.3	66	38.8	66	41.2	69	33.3	69	36.5	69	38.7			50
55	64	28.9	64	32.1	64	35.6	67	30.9	67	34.0	67	32.1			55
60	61	26.8	61	26.8	61	30.3	65	28.8	65	31.1	65	26.7			60
65	58	24.9	58	22.6	58	25.9	62	26.9	62	26.4	62	22.4			65
70	56	22.9	56	19.0	56	22.4	60	23.9	60	23.1	60	18.9			70
75	53	20.8	53	15.9	53	19.3	58	21.3	58	20.3	58	15.9			75
80	50	18.8	50	13.3	50	16.6	55	17.7	55	17.5	55	13.3			80
85	47	17.3	47	11.2	47	14.5	53	16.9	53	15.4	53	11.2			85
90	43	15.3	43	9.3	43	12.6	50	15.0	50	13.3	50	9.3			90
95	40	13.5	40	7.6	40	10.9	47	13.3	47	11.6	47	7.6			95
100	36	11.9	36	6.2	36	9.3	44	11.6	44	10.2	44	6.1			100
110	27	9.4	27	3.7	27	6.8	38	9.1	38	7.6	38	3.5			110
120							29	7.0	29	5.4	29	3.2			120
130						18	5.3	18	3.9			3.2			130
140												2.3			140
150															150
160															160
Telescoping sequence %															
Tel. 1	0	93	46	0	46	93	0	93	46	46	93	93	100	Tel. 1	
Tel. 2	0	46	46	46	46	93	93	93	93	93	93	93	100	Tel. 2	
Tel. 3	93	46	46	93	46	46	93	93	93	93	93	93	100	Tel. 3	
Tel. 4	93	46	46	93	93	46	46	93	46	93	93	93	100	Tel. 4	
Tel. 5	93	46	93	93	93	46	46	93	46	46	93	46	93	Tel. 5	

Operation and maintenance of this machine must be in compliance with the information provided in the "Operation and Maintenance Manual" supplied with this machine.





### Counterweight 0 lbs

Work. Radius (ft)	Lifting capacities in 1,000 lbs according per SAE J765 on telescopic boom On outriggers, 360° working area														Work. Radius (ft)
	Outrigger base 27.23 ft														
	Boom length (ft)														
	128.9	128.9	128.9	143.4	143.4	143.3	157.5	157.5	157.5	171.9	171.9	186.0	196.9		
9															9
10															10
12															12
14															14
16															16
18															18
20	81	57.2	81	91.3	81	71.0	82	49.4	82	54.0					20
25	78	51.6	78	87.0	78	68.0	80	49.4	80	53.7					25
30	76	45.9	76	66.3	76	61.4	78	47.2	78	50.1					30
35	74	41.4	74	47.8	74	49.1	76	42.8	76	45.9					35
40	72	37.4	72	36.5	72	37.8	74	38.8	74	38.9					40
45	69	33.0	69	28.4	69	31.8	71	34.0	71	32.5					45
50	66	28.4	66	22.2	66	26.0	69	28.4	69	26.8					50
55	64	24.0	64	17.3	64	21.0	67	23.6	67	22.0					55
60	61	20.1	61	13.3	61	17.1	65	19.7	65	18.1					60
65	58	16.9	58	10.3	58	14.0	62	16.5	62	14.7					65
70	56	14.5	56	7.9	56	11.3	60	13.9	60	12.3					70
75	53	12.2	53	5.8	53	9.1	58	11.6	58	10.1					75
80	50	10.2	50	3.9	50	7.3	55	9.7	55	8.2					80
85	47	8.7			47	5.6	53	8.0	53	6.7					85
90	43	7.2			43	4.4	50	6.8	50	5.2					90
95	40	5.9			40	3.3	47	5.7	47	3.9					95
100	36	4.8					44	4.6	44	2.7					100
110	27	3.1					38	2.9							110
120															120
130															130
140															140
150															150
Telescoping sequence %															
Tel. 1	0	93	46	0	46	93	0	93	46	46	93	93	100	Tel. 1	
Tel. 2	0	46	46	46	46	93	93	93	93	93	93	93	100	Tel. 2	
Tel. 3	93	46	46	93	46	46	93	93	93	93	93	93	100	Tel. 3	
Tel. 4	93	46	46	93	93	46	93	46	93	93	93	93	100	Tel. 4	
Tel. 5	93	46	93	93	93	46	93	46	46	93	46	93	100	Tel. 5	

Operation and maintenance of this machine must be in compliance with the information provided in the "Operation and Maintenance Manual" supplied with this machine.

### Counterweight 81,570 lbs

Work. Radius (ft)	Lifting capacities in 1,000 lbs according per SAE J765 on telescopic boom On outriggers, 360° working area														Work. Radius (ft)
	Outrigger base 18.37 ft														
	Boom length (ft)														
	128.9	128.9	128.9	143.4	143.4	143.3	157.5	157.5	157.5	171.9	171.9	186.0	196.9		
9															9
10															10
12															12
14															14
16															16
18															18
20	81	57.2	81	91.3	81	71.0	82	49.4	82	54.0					20
25	78	51.6	78	91.1	78	68.0	80	49.4	80	53.7					25
30	76	45.9	76	77.8	76	61.9	78	47.2	78	50.1					30
35	74	41.4	74	64.4	74	56.8	76	42.8	76	45.9					35
40	72	37.5	72	54.1	72	52.4	74	39.1	74	42.2					40
45	69	34.1	69	45.8	69	48.6	71	36.1	71	39.1					45
50	66	31.3	66	39.8	66	43.2	69	33.3	69	36.5					50
55	64	28.9	64	34.4	64	37.6	67	30.9	67	34.2					55
60	61	26.8	61	29.4	61	32.5	65	28.8	65	31.8					60
65	58	24.9	58	25.2	58	28.3	62	26.9	62	28.8					65
70	56	23.4	56	21.7	56	24.8	60	25.2	60	25.5					70
75	53	21.9	53	18.9	53	21.9	58	23.3	58	22.5					75
80	50	20.4	50	16.4	50	19.3	55	21.3	55	20.0					80
85	47	19.3	47	14.2	47	17.1	53	19.1	53	17.8					85
90	43	17.4	43	12.4	43	15.1	50	17.2	50	15.9					90
95	40	15.8	40	10.6	40	13.4	47	15.5	47	14.2					95
100	36	14.3	36	9.1	36	11.9	44	13.9	44	12.6					100
110	27	11.6	27	6.5	27	9.4	38	11.4	38	10.1					110
120							29	9.2	29	8.0					120
130							18	7.5	18	6.2					130
140															140
150															150
Telescoping sequence %															
Tel. 1	0	93	46	0	46	93	0	93	46	46	93	93	100	Tel. 1	
Tel. 2	0	46	46	46	46	93	93	93	93	93	93	93	100	Tel. 2	
Tel. 3	93	46	46	93	46	46	93	93	93	93	93	93	100	Tel. 3	
Tel. 4	93	46	46	93	93	46	93	46	93	93	93	93	100	Tel. 4	
Tel. 5	93	46	93	93	93	46	93	46	46	93	46	93	100	Tel. 5	

Operation and maintenance of this machine must be in compliance with the information provided in the "Operation and Maintenance Manual" supplied with this machine.

### Counterweight 55,115 lbs

Work. Radius (ft)	Lifting capacities in 1,000 lbs according per SAE J765 on telescopic boom On outriggers, 360° working area Outrigger base 18.37 ft																				Work. Radius (ft)	
	Boom length (ft)																					
	43.3	57.7	57.7	71.9	71.9	71.9	71.9	83.3	86.3	86.3	100.4	100.4	100.4	100.4	114.8	114.8	114.8	114.8	114.8	114.8		
9	71	400.0*																			9	
10	70	350.5*	280.5*	76	117.0	76	264.0*	79	85.5	79	120.5	79	255.0*	79	223.0	81	88.9	81	116.5	81	196.5	10
12	67	315.5*	251.5*	73	110.0	73	251.5*	77	79.7	77	118.5	77	243.5*	77	223.0	80	83.6	80	116.5	80	196.5	12
14	64	267.0*	227.0*	71	104.0	71	221.5	75	74.6	75	112.5	75	200.5	75	205.0	78	78.9	78	116.5	78	182.0	14
16	61	233.5	204.0	69	98.5	69	185.0	73	69.9	73	107.5	73	181.5	73	170.0	77	74.3	77	113.5	77	153.0	16
18	58	208.5	175.0	67	93.7	67	157.0	72	65.9	72	102.5	72	152.0	72	145.5	76	70.2	76	109.0	76	132.0	18
20	54	186.5	145.5	65	89.1	65	132.5	71	62.1	71	98.3	71	120.0	71	124.5	74	66.2	74	104.5	74	113.5	20
25	45	148.0	97.3	59	79.7	59	95.5	66	54.6	66	87.4	66	87.9	66	92.1	71	58.1	71	91.5	71	84.4	25
30	32	117.0	69.4	52	71.5	52	69.2	62	48.5	62	76.7	62	67.1	62	70.8	67	51.5	67	73.8	67	65.2	30
35				45	57.6	45	52.7	56	43.7	56	60.0	56	51.1	56	54.7	63	46.2	63	60.0	63	52.5	35
40				37	46.1	37	41.5	51	39.7	51	48.5	51	40.0	51	43.5	59	41.9	59	49.0	59	42.0	40
45				26	37.7	26	33.3	45	36.5	45	40.0	45	31.9	45	35.1	55	38.4	55	60.4	55	33.7	45
50								39	32.7	39	33.4	39	25.8	39	28.7	50	34.6	50	33.9	50	27.4	50
55								31	28.5	31	28.2	31	20.7	31	23.6	46	30.4	46	28.6	46	22.4	55
60								22	24.1	22	23.9	22	16.4	22	19.2	41	26.0	41	24.3	41	18.3	60
65																35	22.5	35	20.9	35	15.0	65
70																27	19.7	27	18.1	27	12.2	70
75																20	17.0	20	15.5	20	9.5	75
80																						80
85																						85
90																						90
95																						95
100																						100
110																						110
120																						120
130																						130
140																						140
150																						150
Telescoping sequence %																						
Tel. 1	0	0	0	0	0	0	46	0	0	0	46	0	0	93	0	46	93	Tel. 1				
Tel. 2	0	0	46	0	0	46	46	0	0	46	0	46	46	0	46	46	0	46	Tel. 2			
Tel. 3	0	0	0	0	0	0	46	0	46	46	0	46	46	0	46	46	46	46	Tel. 3			
Tel. 4	0	0	0	0	46	0	0	46	46	0	93	46	0	93	46	0	93	46	Tel. 4			
Tel. 5	0	46	0	93	46	0	0	0	93	46	0	93	46	0	93	46	0	93	Tel. 5			

1) Over rear with superstructure pin engaged

\*With additional lifting equipment

Operation and maintenance of this machine must be in compliance with the information provided in the "Operation and Maintenance Manual" supplied with this machine

### Counterweight 0 lbs

Work. Radius (ft)	Lifting capacities in 1,000 lbs according per SAE J765 on telescopic boom On outriggers, 360° working area Outrigger base 18.37 ft																				Work. Radius (ft)	
	Boom length (ft)																					
	43.3	57.7	57.7	71.9	71.9	71.9	71.9	83.3	86.3	86.3	100.4	100.4	100.4	100.4	114.8	114.8	114.8	114.8	114.8	114.8		
9	70		242.0	76	117.0	76	192.0	79	85.5	79	120.5	79	155.0	79	162.0	81	88.9	81	116.5	81	134.6	9
10	67		164.5	73	110.0	73	137.0	77	79.7	77	117.5	77	114.0	77	120.5	80	83.6	80	111.5	80	102.7	10
12	64		120.5	71	104.0	71	103.5	75	74.6	75	103.0	75	88.7	75	94.4	78	78.9	78	93.0	78	81.6	12
14	61		93.1	69	89.9	69	82.1	73	69.9	73	84.3	73	71.2	73	76.2	77	74.3	77	77.2	77	66.5	14
16	58		76.4	67	75.4	67	68.1	72	65.7	72	71.6	72	59.2	72	64.1	76	66.9	76	66.0	76	55.7	16
18	54		62.3	65	62.8	65	56.0	71	60.9	71	60.5	71	48.6	71	53.5	74	58.9	74	56.2	74	46.2	18
20	54		39.9	59	43.8	59	37.8	66	43.6	66	43.3	66	32.7	66	36.7	71	43.3	71	40.9	71	32.3	20
25	45		25.8	52	31.0	52	25.6	62	32.5	62	32.3	62	22.4	62	26.2	67	32.8	67	30.6	67	22.5	25
30	32			45	22.3	45	17.4	56	24.9	56	24.6	56	15.6	56	19.2	63	25.9	63	23.8	63	16.4	30
35				37	16.4	37	11.8	51	19.0	51	18.8	51	10.3	51	13.6	59	20.8	59	18.7	59	11.7	35
40				26	12.1	26	7.6	45	14.5	45	14.3	45	6.3	45	9.4	55	16.5	55	14.6	55	8.0	40
45								39	11.2	39	10.9					39	6.3	50	13.1	50	4.3	45
50								31	8.5	31	8.2					31	3.4	46	10.3	46	8.5	50
55								22	6.2	22	6.0							41	8.0	41	6.3	55
60																		35	6.2	35	4.6	60
65																		27	4.8	27	3.1	65
70																		20	3.4	20		70
75																						75
80																						80
85																						85
90																						90
95																						95
100																						100
110																						110
120																						120
130																						130
140																						140
150																						150
Telescoping sequence %																						
Tel. 1	0	0	0	0	0	0	46	0	0	0	46	0	0	93	0	46	93	Tel. 1				
Tel. 2	0	0	46	0	0	46	46	0	0	46	0	46	46	0	46	46	0	46	Tel. 2			
Tel. 3	0	0	0	0	0	0	46	0	46	46	0	46	46	0	46	46	46	46	Tel. 3			
Tel. 4	0	0	0	0	46	0	0	46	46	0	93	46	0	93	46	0	93	46	Tel. 4			
Tel. 5	0	46	0	93	46	0	0	0	93	46	0	93	46	0	93	46	0	93	Tel. 5			

1) Over rear with superstructure pin engaged

\*With additional lifting equipment

Operation and maintenance of this machine must be in compliance with the information provided in the "Operation and Maintenance Manual" supplied with this machine

### Counterweight 55,115 lbs

Work. Radius (ft)	Lifting capacities in 1,000 lbs according per SAE J765 on telescopic boom On outriggers, 360° working area Outrigger base 18.37 ft															Work. Radius (ft)												
	Boom length (ft)																											
	128.9		128.9		128.9		143.4		143.4		143.3		157.5		157.5		157.5		171.9		171.9		186.0		196.9			
9																										9		
10																											10	
12																											12	
14																											14	
16																											16	
18																											18	
20	81	57.2	81	90.4	81	71.0	82	49.4	82	54.0	82	73.6															20	
25	78	51.6	78	74.8	78	68.0	80	49.4	80	53.7	80	69.4	81	43.0	81	59.3	81	49.2									25	
30	76	45.9	76	58.9	76	61.6	78	47.2	78	50.1	78	56.9	80	43.0	80	55.0	80	49.2	81	38.8	81	47.6	82	37.5			30	
35	74	41.4	74	48.8	74	52.4	76	42.8	76	45.9	76	46.7	78	42.0	78	45.5	78	47.1	79	38.8	79	44.5	80	37.5	81	30.9	35	
40	72	37.5	72	40.4	72	44.1	74	39.1	74	41.9	74	38.9	76	39.5	76	38.1	76	40.5	78	38.3	78	37.9	79	36.9	80	30.9	40	
45	69	34.1	69	34.2	69	37.6	71	36.1	71	36.9	71	32.7	74	36.5	74	32.2	74	34.4	75	34.3	75	32.1	77	32.2	78	30.9	45	
50	66	31.3	66	29.2	66	32.5	69	33.3	69	32.4	69	28.0	72	32.1	72	27.5	72	29.9	74	30.2	74	27.7	76	28.0	77	27.4	50	
55	64	28.9	64	24.8	64	28.0	67	29.9	67	28.4	67	24.0	70	28.1	70	23.7	70	26.0	72	26.5	72	23.9	74	24.3	75	23.8	55	
60	61	26.4	61	20.7	61	23.8	65	26.0	65	24.7	65	20.5	68	24.8	68	20.4	68	22.6	71	23.1	71	20.7	73	21.1	74	20.7	60	
65	58	22.9	58	17.4	58	20.3	62	22.7	62	21.2	62	17.2	66	21.8	66	17.7	66	19.8	68	20.4	68	18.0	70	18.6	72	18.2	65	
70	56	20.1	56	14.6	56	17.5	60	19.8	60	18.4	60	14.4	64	19.0	64	15.1	64	17.0	67	18.0	67	15.7	69	16.4	71	15.9	70	
75	53	17.7	53	12.2	53	15.1	58	17.3	58	16.0	58	12.1	62	16.5	62	12.7	62	14.6	65	15.6	65	13.5	67	14.2	69	14.0	75	
80	50	15.6	50	10.2	50	13.0	55	15.2	55	13.9	55	10.1	59	14.3	59	10.6	59	12.5	63	13.5	63	11.4	66	12.1	68	12.4	80	
85	47	13.8	47	8.5	47	11.3	53	13.3	53	12.0	53	8.3	57	12.7	57	8.7	57	10.7	61	11.8	61	9.6	64	10.3	66	10.7	85	
90	43	12.1	43	7.0	43	9.8	50	11.8	50	10.5	50	6.7	55	11.0	55	7.2	55	9.2	59	10.3	59	8.1	62	8.7	65	9.2	90	
95	40	10.7	40	5.6	40	8.4	47	10.4	47	9.1	47	5.4	53	9.6	53	5.9	53	7.9	57	8.9	57	6.8	60	7.3	63	7.8	95	
100	36	9.6	36	4.3	36	7.1	44	9.1	44	7.8	44	4.3	50	8.4	50	4.7	50	6.7	54	7.6	54	5.6	58	6.0	61	6.5	100	
110	27	7.4			27	4.9	38	6.9	38	5.8			45	6.3			45	4.5	50	5.6	50	3.4	54	4.0	57	4.5	110	
120							29	5.3	29	4.1			39	4.5			39	2.8	45	3.7					53	2.8	120	
130							18	3.9					32	3.0														130
140																												140
150																												150
160																												160
170																												170
180																												180
190																												190
Telescoping sequence %																												
Tel. 1	0	93	46	0	46	93	0	93	46	46	93	46	46	93	93	93	93	93	93	93	93	93	100	Tel. 1				
Tel. 2	0	46	46	46	46	93	93	93	93	93	93	93	93	93	93	93	93	93	93	93	93	93	100	Tel. 2				
Tel. 3	93	46	46	93	46	46	93	93	93	93	93	93	93	93	93	93	93	93	93	93	93	93	100	Tel. 3				
Tel. 4	93	46	46	93	93	93	46	93	46	93	46	93	46	93	46	93	46	93	46	93	46	93	100	Tel. 4				
Tel. 5	93	46	93	93	93	93	46	93	46	46	93	46	46	93	46	46	93	46	93	46	93	100	Tel. 5					

Operation and maintenance of this machine must be in compliance with the information provided in the "Operation and Maintenance Manual" supplied with this machine.

## ATF160G-5 WORKING RANGE CHART

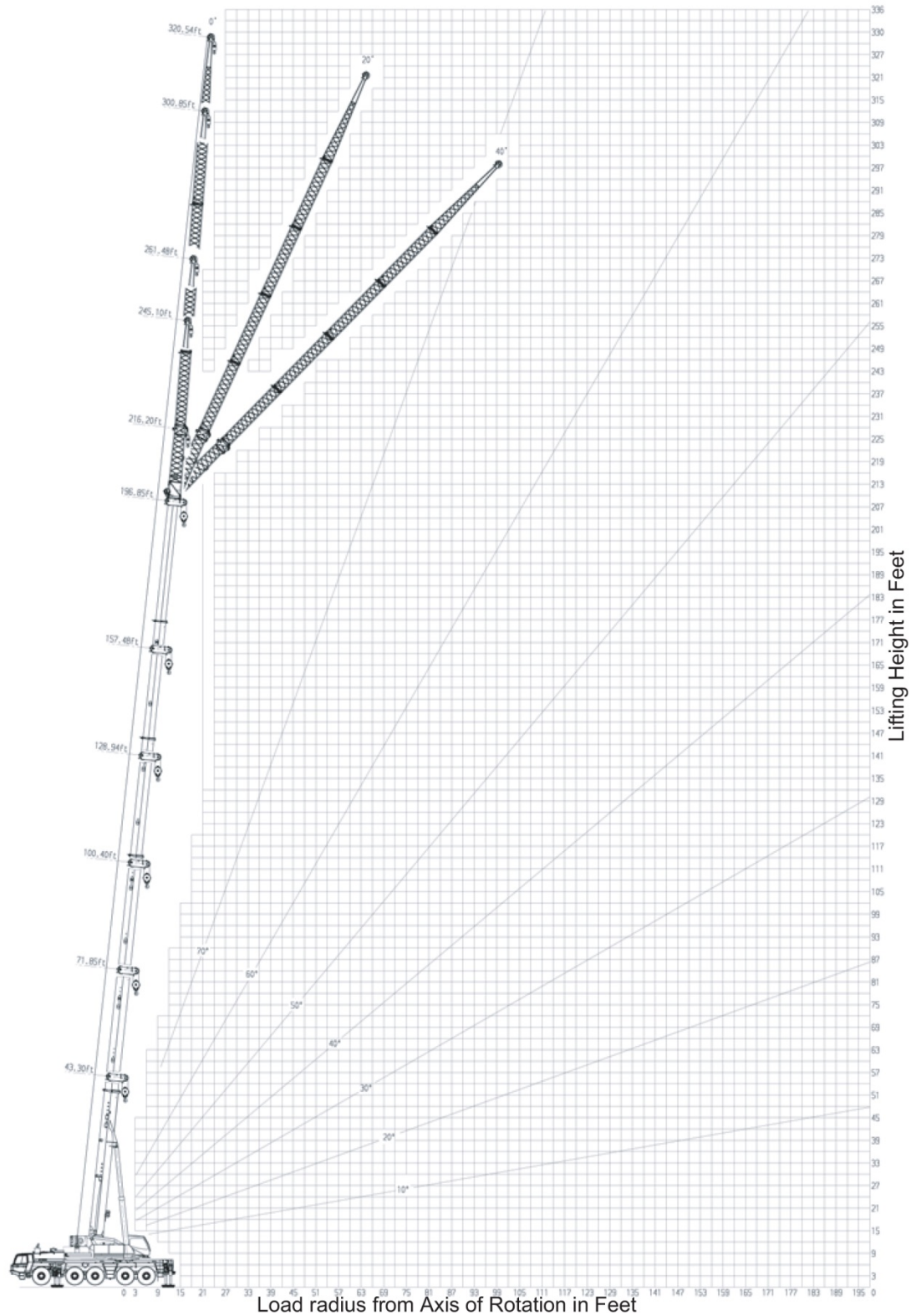

**NOTE:** Boom and jib geometry shown are for unloaded condition and machine standing level on firm supporting surface. Boom deflection and subsequent radius and boom angle change must be accounted for when applying load to hook.

### Counterweight 112,435 lbs

Working Radius (ft)	Lifting capacities in 1,000 lbs according per SAE J765 on fly jib 17.72 ft On outriggers, 360° working area Outrigger base 27.23 ft												Working Radius (ft)						
	Boom length 43.3 ft			Boom length 43.3 ft to 186.0 ft			Boom length 43.3 ft to 196.9 ft												
	Fly jib 17.72 ft offset			Fly jib 17.72 ft offset			Fly jib 17.72 ft offset												
	0°	20°	40°	5°	20°	40°	5°	20°	40°										
10	76	72.8													10				
12	74	68.7	79	51.4											12				
14	72	65.7	77	49.3											14				
16	70	63.0	75	47.9	79	40.3									16				
18	68	60.0	74	46.4	78	39.8									18				
20	66	57.0	72	45.0	76	39.4									20				
25	61	51.8	66	42.6	70	38.2									25				
30	55	47.3	60	40.6	63	37.2									30				
35	49	43.9	54	38.9	57	37.0	80	23.0							35				
40	42	41.2	47	37.8	50	37.0	79	21.9	81	20.2			80	20.4	40				
45	34	39.0	39	37.2			78	20.9	79	19.3			79	19.4	80	18.0	45		
50	22	37.6					77	19.9	78	18.5	80	17.5	78	18.5	79	17.3	80	16.4	50
55							75	19.1	77	17.7	78	16.9	76	17.7	78	16.6	79	15.8	55
60							74	18.4	76	17.1	77	16.4	75	17.1	77	16.0	78	15.3	60
65							73	17.5	74	16.6	75	15.9	74	16.4	75	15.5	76	14.8	65
70							72	16.8	73	16.1	74	15.4	73	15.7	74	15.0	75	14.3	70
75							70	16.3	71	15.6	72	14.9	71	15.1	73	14.5	74	13.9	75
80							69	15.7	70	15.1	71	14.5	70	14.6	72	14.0	73	13.6	80
85							67	15.0	69	14.6	69	14.1	69	14.1	70	13.5	71	13.2	85
90							66	14.5	68	14.1	68	13.8	68	13.6	69	13.1	70	12.9	90
95							64	14.1	66	13.6	66	13.4	66	13.1	67	12.7	68	12.5	95
100							63	13.7	64	13.1	65	12.9	65	12.7	66	12.2	67	12.0	100
110							59	12.9	60	12.4	61	12.2	61	12.0	63	11.6	63	11.3	110
120							56	12.2	57	11.8	58	11.6	58	11.3	59	11.0	60	10.9	120
130							53	11.5	54	11.3	54	11.1	55	10.8	56	10.4	57	10.4	130
140							49	11.0	50	10.8	51	10.7	52	10.4	53	10.1	54	9.9	140
150							45	10.6	46	10.4	46	10.4	49	9.9	50	9.6	50	9.5	150
160							41	10.1	42	9.9	42	10.1	45	9.4	46	9.1	46	9.1	160
170							35	8.9	36	8.9			40	8.8	41	8.6	41	8.6	170
180							29	7.7	29	7.6			35	7.7	36	7.7			180
190													29	6.4	29	6.4			190
200													22	5.1	22	5.1			200
210																			210
220																			220
Telescoping sequence %																			
Tel. 1	0			93			100			Tel. 1									
Tel. 2	0			93			100			Tel. 2									
Tel. 3	0			93			100			Tel. 3									
Tel. 4	0			93			100			Tel. 4									
Tel. 5	0			93			100			Tel. 5									

Operation and maintenance of this machine must be in compliance with the information provided in the "Operation and Maintenance Manual" supplied with this machine.



### Counterweight 81,570 lbs

Working Radius (ft)	Lifting capacities in 1,000 lbs according per SAE J765 on fly jib 17.72 ft On outriggers, 360° working area Outrigger base 27.23 ft												Working Radius (ft)						
	Boom length 43.3 ft			Boom length 43.3 ft to 186.0 ft			Boom length 43.3 ft to 196.9 ft												
	Fly jib 17.72 ft offset			Fly jib 17.72 ft offset			Fly jib 17.72 ft offset												
	0°	20°	40°	5°	20°	40°	5°	20°	40°										
10	76	72.8													10				
12	74	68.7	79	51.4											12				
14	72	65.7	77	49.3											14				
16	70	63.0	75	47.9	79	40.3									16				
18	68	60.0	74	46.4	78	39.8									18				
20	66	57.0	72	45.0	76	39.4									20				
25	61	51.8	66	42.6	70	38.2									25				
30	55	47.3	60	40.6	63	37.2									30				
35	49	43.9	54	38.9	57	37.0	80	23.0							35				
40	42	41.2	47	37.8	50	37.0	79	21.9	81	20.2		80	20.4		40				
45	34	39.0	39	37.2			78	20.9	79	19.3		79	19.4	80	18.0	45			
50	22	37.6					77	19.9	78	18.5	80	17.5	78	18.5	79	17.3	80	16.4	50
55							75	19.1	77	17.7	78	16.9	76	17.7	78	16.6	79	15.8	55
60							74	18.4	76	17.1	77	16.4	75	17.1	77	16.0	78	15.3	60
65							73	17.5	74	16.6	75	15.9	74	16.4	75	15.5	76	14.8	65
70							72	16.8	73	16.1	74	15.4	73	15.7	74	15.0	75	14.3	70
75							70	16.3	71	15.6	72	14.9	71	15.1	73	14.5	74	13.9	75
80							69	15.7	70	15.1	71	14.5	70	14.6	72	14.0	73	13.6	80
85							67	15.0	69	14.6	69	14.1	69	14.1	70	13.5	71	13.2	85
90							66	14.5	68	14.1	68	13.8	68	13.6	69	13.1	70	12.9	90
95							64	14.1	66	13.6	66	13.4	66	13.1	67	12.7	68	12.5	95
100							63	13.7	64	13.1	65	12.9	65	12.7	66	12.2	67	12.0	100
110							59	12.9	60	12.4	61	12.2	61	12.0	63	11.6	63	11.3	110
120							56	12.2	57	11.8	58	11.6	58	11.3	59	11.0	60	10.9	120
130							53	11.5	54	11.3	54	11.1	55	10.8	56	10.4	57	10.4	130
140							49	10.0	50	10.1	51	10.1	52	9.8	53	9.8	54	9.9	140
150							45	8.3	46	8.5	46	8.7	49	8.2	50	8.5	50	8.7	150
160							41	6.7	42	6.9	42	6.8	45	6.5	46	6.9	46	6.9	160
170							35	5.2	36	5.2			40	5.2	41	5.2	41	5.2	170
180							29	3.8	29	3.8			35	3.8	36	3.8			180
190																			190
200																			200
Telescoping sequence %																			
Tel. 1	0			93			100			Tel. 1									
Tel. 2	0			93			100			Tel. 2									
Tel. 3	0			93			100			Tel. 3									
Tel. 4	0			93			100			Tel. 4									
Tel. 5	0			93			100			Tel. 5									

Operation and maintenance of this machine must be in compliance with the information provided in the "Operator and Maintenance Manual" supplied with this machine.



### Counterweight 81,570 lbs

Working Radius (ft)	Lifting capacities in 1,000 lbs according per SAE J765 on fly jib 17.72 ft On outriggers, 360° working area <b>Outrigger base 18.37 ft</b>												Working Radius (ft)						
	Boom length 43.3 ft			Boom length 43.3 ft to 186.0 ft			Boom length 43.3 ft to 196.9 ft												
	Fly jib 17.72 ft offset			Fly jib 17.72 ft offset			Fly jib 17.72 ft offset												
	0°	20°	40°	5°	20°	40°	5°	20°	40°										
	∠	∠	∠	∠	∠	∠	∠	∠	∠										
10	76	72.8											10						
12	74	68.7	79	51.4									12						
14	72	65.7	77	49.3									14						
16	70	63.0	75	47.9	79	40.3							16						
18	68	60.0	74	46.4	78	39.8							18						
20	66	57.0	72	45.0	76	39.4							20						
25	61	51.8	66	42.6	70	38.2							25						
30	55	47.3	60	40.6	63	37.2							30						
35	49	43.9	54	38.9	57	37.0	80	23.0					35						
40	42	41.2	47	37.8	50	37.0	79	21.9	81	20.2		80	20.4	40					
45	34	39.0	39	37.2			78	20.9	79	19.3		79	19.4	80	18.0	45			
50	22	37.6					77	19.9	78	18.5	80	17.5	78	18.5	79	17.3	80	16.4	50
55							75	19.1	77	17.7	78	16.9	76	17.7	78	16.6	79	15.8	55
60							74	18.4	76	17.1	77	16.4	75	17.1	77	16.0	78	15.3	60
65							73	17.5	74	16.6	75	15.9	74	16.4	75	15.5	76	14.8	65
70							72	16.8	73	16.1	74	15.4	73	15.7	74	15.0	75	14.3	70
75							70	16.3	71	15.6	72	14.9	71	15.1	73	14.5	74	13.9	75
80							69	15.7	70	15.1	71	14.5	70	14.6	72	14.0	73	13.6	80
85							67	15.0	69	14.6	69	14.1	69	14.1	70	13.5	71	13.2	85
90							66	14.2	68	14.1	68	13.8	68	13.6	69	13.1	70	12.9	90
95							64	12.9	66	13.3	66	13.4	66	12.6	67	12.7	68	12.5	95
100							63	11.4	64	12.1	65	12.5	65	11.3	66	11.9	67	11.9	100
110							59	8.9	60	9.4	61	9.7	61	8.7	63	9.4	63	9.7	110
120							56	6.7	57	7.1	58	7.3	58	6.7	59	7.1	60	7.3	120
130							53	5.0	54	5.3	54	5.5	55	4.8	56	5.3	57	5.5	130
140							49	3.5	50	3.7	51	4.0	52	3.5	53	3.7	54	4.0	140
150																			150
160																			160
170																			170
180																			180
190																			190
200																			200
Telescoping sequence %																			
Tel. 1	0			93			100			Tel. 1									
Tel. 2	0			93			100			Tel. 2									
Tel. 3	0			93			100			Tel. 3									
Tel. 4	0			93			100			Tel. 4									
Tel. 5	0			93			100			Tel. 5									

Operation and maintenance of this machine must be in compliance with the information provided in the "Operation and Maintenance Manual" supplied with this machine.



### Counterweight 55,115 lbs

Working Radius (ft)	Lifting capacities in 1,000 lbs according per SAE J765 on fly jib 17.72 ft On outriggers, 360° working area <b>Outrigger base 27.23 ft</b>												Working Radius (ft)						
	Boom length 43.3 ft				Boom length 43.3 ft to 186.0 ft				Boom length 43.3 ft to 196.9 ft										
	Fly jib 17.72 ft offset				Fly jib 17.72 ft offset				Fly jib 17.72 ft offset										
	0°	20°	40°		5°	20°	40°		5°	20°	40°								
10	76	72.8												10					
12	74	68.7	79	51.4										12					
14	72	65.7	77	49.3										14					
16	70	63.0	75	47.9	79	40.3								16					
18	68	60.0	74	46.4	78	39.8								18					
20	66	57.0	72	45.0	76	39.4								20					
25	61	51.8	66	42.6	70	38.2								25					
30	55	47.3	60	40.6	63	37.2								30					
35	49	43.9	54	38.9	57	37.0	80	23.0						35					
40	42	41.2	47	37.8	50	37.0	79	21.9	81	20.2				40					
45	34	39.0	39	37.2			78	20.9	79	19.3				45					
50	22	37.6					77	19.9	78	18.5	80	17.5		50					
55							75	19.1	77	17.7	78	16.9	76	17.7	78	16.6	79	15.8	55
60							74	18.4	76	17.1	77	16.4	75	17.1	77	16.0	78	15.3	60
65							73	17.5	74	16.6	75	15.9	74	16.4	75	15.5	76	14.8	65
70							72	16.8	73	16.1	74	15.4	73	15.7	74	15.0	75	14.3	70
75							70	16.3	71	15.6	72	14.9	71	15.1	73	14.5	74	13.9	75
80							69	15.7	70	15.1	71	14.5	70	14.6	72	14.0	73	13.6	80
85							67	15.0	69	14.6	69	14.1	69	14.1	70	13.5	71	13.2	85
90							66	14.5	68	14.1	68	13.8	68	13.6	69	13.1	70	12.9	90
95							64	14.1	66	13.6	66	13.4	66	13.1	67	12.7	68	12.5	95
100							63	13.7	64	13.1	65	12.9	65	12.7	66	12.2	67	12.0	100
110							59	12.0	60	12.4	61	12.2	61	11.8	63	11.6	63	11.3	110
120							56	9.5	57	10.0	58	10.5	58	9.5	59	10.0	60	10.5	120
130							53	7.3	54	7.8	54	8.0	55	7.3	56	7.8	57	8.0	130
140							49	5.6	50	5.9	51	6.1	52	5.6	53	5.9	54	6.1	140
150							45	4.0	46	4.2	46	4.3	49	4.0	50	4.2	50	4.4	150
160																			160
Telescoping sequence %																			
Tel. 1	0				93				100				Tel. 1						
Tel. 2	0				93				100				Tel. 2						
Tel. 3	0				93				100				Tel. 3						
Tel. 4	0				93				100				Tel. 4						
Tel. 5	0				93				100				Tel. 5						

Operation and maintenance of this machine must be in compliance with the information provided in the "Operation and Maintenance Manual" supplied with this machine.

### Counterweight 55,115 lbs

Working Radius (ft)	Lifting capacities in 1,000 lbs according per SAE J765 on fly jib 17.72 ft On outriggers, 360° working area <b>Outrigger base 18.37 ft</b>												Working Radius (ft)						
	Boom length 43.3 ft				Boom length 43.3 ft to 186.0 ft				Boom length 43.3 ft to 196.9 ft										
	Fly jib 17.72 ft offset				Fly jib 17.72 ft offset				Fly jib 17.72 ft offset										
	0°	20°	40°		5°	20°	40°		5°	20°	40°								
10	76	72.8												10					
12	74	68.7	79	51.4										12					
14	72	65.7	77	49.3										14					
16	70	63.0	75	47.9	79	40.3								16					
18	68	60.0	74	46.4	78	39.8								18					
20	66	57.0	72	45.0	76	39.4								20					
25	61	51.8	66	42.6	70	38.2								25					
30	55	47.3	60	40.6	63	37.2								30					
35	49	43.9	54	38.9	57	37.0	80	23.0						35					
40	42	41.2	47	37.8	50	37.0	79	21.9	81	20.2				40					
45	34	39.0	39	37.2			78	20.9	79	19.3				45					
50	22	33.4					77	19.9	78	18.5	80	17.5	78	18.5	79	17.3	80	16.4	50
55							75	19.1	77	17.7	78	16.9	76	17.7	78	16.6	79	15.8	55
60							74	18.4	76	17.1	77	16.4	75	17.1	77	16.0	78	15.3	60
65							73	17.5	74	16.6	75	15.9	74	16.4	75	15.5	76	14.8	65
70							72	16.8	73	16.1	74	15.4	73	15.7	74	15.0	75	14.3	70
75							70	16.3	71	15.6	72	14.9	71	15.1	73	14.5	74	13.9	75
80							69	15.7	70	15.1	71	14.5	70	14.6	72	14.0	73	13.6	80
85							67	15.0	69	14.6	69	14.1	69	14.1	70	13.5	71	13.2	85
90							66	14.5	68	14.1	68	13.8	68	13.6	69	13.1	70	12.9	90
95							64	14.1	66	13.6	66	13.4	66	13.1	67	12.7	68	12.5	95
100							63	13.7	64	13.1	65	12.9	65	12.7	66	12.2	67	12.0	100
110							59	12.0	60	12.4	61	12.2	61	11.8	63	11.6	63	11.3	110
120							56	9.5	57	10.0	58	10.5	58	9.5	59	10.0	60	10.5	120
130							53	7.3	54	7.8	54	8.0	55	7.3	56	7.8	57	8.0	130
140							49	5.6	50	5.9	51	6.1	52	5.6	53	5.9	54	6.1	140
150							45	4.0	46	4.2	46	4.3	49	4.0	50	4.2	50	4.4	150
160																			160
Telescoping sequence %																			
Tel. 1	0				93				100				Tel. 1						
Tel. 2	0				93				100				Tel. 2						
Tel. 3	0				93				100				Tel. 3						
Tel. 4	0				93				100				Tel. 4						
Tel. 5	0				93				100				Tel. 5						

Operation and maintenance of this machine must be in compliance with the information provided in the "Operation and Maintenance Manual" supplied with this machine.

### Counterweight 55,115 lbs

Lifting capacities in 1,000 lbs according per SAE J765 on fly jib 43.3 ft  
On outriggers, 360° working area  
**Outrigger base 18.37 ft**

Working Radius (ft)	Boom length 43.3 ft to 186.0 ft						Boom length 43.3 ft to 196.9 ft						Working Radius (ft)		
	Fly jib 43.3 ft offset			Fly jib 43.3 ft offset			Fly jib 43.3 ft offset			Fly jib 43.3 ft offset					
	0°	20°	40°	0°	20°	40°	0°	20°	40°	0°	20°	40°			
40	80	16.5							81	13.9					40
45	79	16.5							79	13.9					45
50	78	16.0							78	13.9					50
55	77	15.3	81	12.2					78	13.9					55
60	76	14.7	80	11.8					77	13.8	80	11.7			60
65	74	14.2	78	11.5					75	13.3	79	11.5			65
70	73	13.7	77	11.3	80	9.6			74	12.8	78	11.2	80	9.6	70
75	72	13.2	76	11.1	79	9.4			74	12.4	77	10.9	79	9.4	75
80	71	12.4	75	10.8	78	9.3			73	11.8	76	10.7	78	9.2	80
85	70	10.9	73	10.6	76	9.3			71	10.4	74	10.4	77	9.0	85
90	69	9.5	72	10.4	75	9.1			70	9.3	73	10.0	76	9.0	90
95	67	8.4	71	9.8	73	8.9			69	8.1	72	9.5	75	8.9	95
100	66	7.4	70	8.9	72	8.8			68	7.0	71	8.7	74	8.8	100
110	63	5.4	66	6.9	69	8.0			65	5.1	68	6.7	70	7.9	110
120	60	3.9	64	5.0	66	5.9			62	3.5	66	5.0	68	5.9	120
130			61	3.5	63	4.2					63	3.5	65	4.2	130
140															140
150															150
160															160
170															170
180															180
190															190
200															200
210															210
220															220
Telescoping sequence %															
Tel. 1	93						100						Tel. 1		
Tel. 2	93						100						Tel. 2		
Tel. 3	93						100						Tel. 3		
Tel. 4	93						100						Tel. 4		
Tel. 5	93						100						Tel. 5		

Operation and maintenance of this machine must be in compliance with the information provided in the "Operation and Maintenance Manual" supplied with this machine.



### Counterweight 28,660 lbs

Lifting capacities in 1,000 lbs according per SAE J765 on fly jib 17.72 ft On outriggers, 360° working area Outrigger base 27.23 ft												
Working Radius (ft)	Boom length 43.3 ft			Boom length 43.3 ft to 186.0 ft			Boom length 43.3 ft to 196.9 ft			Working Radius (ft)		
	Fly jib 17.72 ft offset			Fly jib 17.72 ft offset			Fly jib 17.72 ft offset					
	0°	20°	40°	5°	20°	40°	5°	20°	40°			
10	76	72.8									10	
12	74	68.7	79	51.4							12	
14	72	65.7	77	49.3							14	
16	70	63.0	75	47.9	79	40.3					16	
18	68	60.0	74	46.4	78	39.8					18	
20	66	57.0	72	45.0	76	39.4					20	
25	61	51.8	66	42.6	70	38.2					25	
30	55	47.3	60	40.6	63	37.2					30	
35	49	43.9	54	38.9	57	37.0	80	23.0			35	
40	42	41.2	47	37.8	50	37.0	79	21.9	81	20.2	40	
45	34	39.0	39	37.2			78	20.9	79	19.3	45	
50	22	37.6					77	19.9	78	18.5	50	
55							75	19.1	77	17.7	55	
60							74	18.4	76	17.1	60	
65							73	17.5	74	16.6	65	
70							72	16.8	73	16.1	70	
75							70	16.3	71	15.6	75	
80							69	15.5	70	15.1	80	
85							67	14.0	69	14.6	85	
90							66	12.2	68	12.8	90	
95							64	10.4	66	11.1	95	
100							63	8.8	64	9.4	100	
110							59	6.1	60	6.9	110	
120							56	4.0	57	4.7	120	
130									54	2.9	130	
140											140	
150											150	
Telescoping sequence %												
Tel. 1	0			93			100			Tel. 1		
Tel. 2	0			93			100			Tel. 2		
Tel. 3	0			93			100			Tel. 3		
Tel. 4	0			93			100			Tel. 4		
Tel. 5	0			93			100			Tel. 5		

Operation and maintenance of this machine must be in compliance with the information provided in the "Operation and Maintenance Manual" supplied with this machine.

### Counterweight 28,660 lbs

Lifting capacities in 1,000 lbs according per SAE J765 on fly jib 43.3 ft On outriggers, 360° working area Outrigger base 27.23 ft												
Working Radius (ft)	Boom length 43.3 ft to 186.0 ft			Boom length 43.3 ft to 196.9 ft			Working Radius (ft)					
	Fly jib 43.3 ft offset			Fly jib 43.3 ft offset								
	0°	20°	40°	0°	20°	40°						
40	80	16.5					81	13.9			40	
45	79	16.5					79	13.9			45	
50	78	16.0					78	13.9			50	
55	77	15.3	81	12.2			78	13.9			55	
60	76	14.7	80	11.8			77	13.8	80	11.7	60	
65	74	14.2	78	11.5			75	13.3	79	11.5	65	
70	73	13.7	77	11.3	80	9.6	74	12.8	78	11.2	70	
75	72	13.2	76	11.1	79	9.4	74	12.4	77	10.9	75	
80	71	12.7	75	10.8	78	9.3	73	12.0	76	10.7	80	
85	70	12.4	73	10.6	76	9.3	71	11.5	74	10.4	85	
90	69	11.9	72	10.4	75	9.1	70	11.1	73	10.0	90	
95	67	11.2	71	10.2	73	8.9	69	10.7	72	9.7	95	
100	66	10.2	70	9.9	72	8.8	68	10.0	71	9.4	100	
110	63	7.5	66	9.0	69	8.6	65	7.5	68	8.8	110	
120	60	5.4	64	6.7	66	7.8	62	5.2	66	6.7	120	
130	58	3.6	61	4.8	63	5.6	60	3.5	63	4.8	130	
140			58	3.3	60	3.8			60	3.2	140	
150											150	
Telescoping sequence %												
Tel. 1	93			100			100			Tel. 1		
Tel. 2	93			100			100			Tel. 2		
Tel. 3	93			100			100			Tel. 3		
Tel. 4	93			100			100			Tel. 4		
Tel. 5	93			100			100			Tel. 5		

Operation and maintenance of this machine must be in compliance with the information provided in the "Operation and Maintenance Manual" supplied with this machine.



## WARNING AND OPERATING INSTRUCTIONS FOR LIFTING CAPACITIES

### GENERAL

- Total rated load shown on the TADANO load rating chart apply only to the machine as originally manufactured and normally equipped by TADANO. Modifications to the machine or use of optional equipment other than that specified can result in a reduction of capacity.
- Hydraulic cranes can be hazardous if improperly operated or maintained. Operation and maintenance of this machine must be in compliance with the information in the **Operation and Maintenance Manual** supplied with the crane. If this manual is missing, order replacement through the distributor.
- The operator and other personnel associated with this machine shall fully acquaint themselves with the latest applicable American National Standards Institute (ANSI) safety standards for cranes.

### SET UP

- Total rated loads shown on the TADANO load rating chart are the maximum allowable crane capacities. They are based on the machine standing level on firm supporting surface under ideal job conditions. Depending on the nature of the supporting surface, it may be necessary to have structural supports under the outrigger floats to spread the load to a larger bearing surface.
- For on outrigger operation, outriggers shall be extended to the dimension according to the TADANO LOAD RATING CHART and secured by pins with tires free of supporting surface, before operating crane.
- Working on tires are travelling with load is not allowed.
- The weight of the auxiliary winch with 3,100 lbs is taken into account as a part of counterweight. Therefore the auxiliary winch must be attached always at the superstructure for crane operation.

### OPERATION

- Total rated loads with outriggers fully extended do not exceed 85% of the tipping loads. Total rated loads with outriggers half extended are determined from the formula:  
total rated load = (tipping load - 0.1 tip reaction) / 1.25
- The crane's structural steelwork is in accordance with DIN 15018, part 3. Design and construction of the crane comply with DIN 15018, part 2 and with F.E.M. regulations.
- Total rated loads above the bold lines in the TADANO load rating chart are based on crane strength and those below the bold lines on crane stability.
- Total rated loads include the weight of main hook block, auxiliary hook ball, sling and other auxiliary lifting devices and all their weights shall be subtracted from the listed capacities to obtain the net load to be lifted.

Hookball/ Hookblock(ton)	11.0	27.5	69.5	88.0	138.0	176.5
No. of sheaves	-	1	3	5	7	9
Weight (lbs.)	440	660	1,325	1,765	2,645	3,525

- Total rated loads are based on freely suspended loads and make no allowance for such factors as the effect of wind, sudden stopping of loads, supporting surface conditions, operating speeds, side loads, etc. Side pull on boom or jib is extremely dangerous.
- Total rated loads do not account for wind on lifted load or boom. Total rated loads and boom length shall be appropriately reduced, when wind velocity is above 18 mph (26 ft/sec.) for main boom operation and above 11 mph (16 ft/sec.) for jib operation.
- Total rated loads at load radius shall not be exceeded. Do not tip the crane to determine allowable loads.
- Do not operate at boom lengths beyond radii or boom angles where no capacities are shown. Crane may overturn without any load on the hook.
- Slewing of the superstructure is admissible only when the crane is supported on half or fully extended outriggers.

- The lifting capacity ratings specified in the TADANO load rating chart apply to the telescopic boom without fly jib fixed in transport position or working position. If the fly jib is secured to the telescopic boom in transport position or working position, the lifting capacities of the telescopic boom are reduced by the values specified below. The weight of the fly jib (3,350 lbs) is detected in terms of a load, and the load moment limiter will shut off earlier.

Jib status	Load rating reduction (tons)									
	Boom length (ft)									
	43.3	71.9	100.4	114.8	143.3	157.5	171.9	186.0	196.8	
17.7ft/43.3ft fly jib, mounted in transport position	0.86	0.33	0.24	0.20	0.20	0.17	0.17	0.13	0.11	
17.7ft fly jib, mounted to the boom head	2.14	1.85	1.64	1.52	1.47	1.44	1.39	1.37	1.35	
43.3ft fly jib, mounted to the boom head	2.92	2.37	2.04	1.82	1.74	1.69	1.65	1.65	1.63	
63.0ft fly jib, mounted to the boom head	3.78	2.89	2.47	2.33	2.25	2.18	2.13	2.08	2.05	
82.7ft fly jib, mounted to the boom head	4.54	3.27	2.89	2.76	2.66	2.57	2.49	2.44	2.39	
102.4ft fly jib, mounted to the boom head	6.56	4.44	3.90	3.63	3.40	3.21	3.08	2.97	2.89	
122.0ft fly jib, mounted to the boom head	8.49	6.45	5.34	4.59	4.17	3.86	3.59	3.37	3.28	

- When making lifts at a load radius not shown, use the next longer radius to determine allowable capacity.
- Load per part line should not exceed 18,650 lbs. for the main winch and for the auxiliary winch.
- Loaded boom angles are approximate. The boom angle before loading should be greater to account for deflection.
- The 43.3ft boom length capacities are based on the telescopic boom being fully retracted. If not fully retracted (less than 57.7ft boom length), use the total rated loads for the 57.7ft boom length according to the telescoping sequence.
- Extension or retraction of the telescopic boom with loads may be attempted within the limits of the TADANO LOAD RATING CHART. The ability to telescope loads is limited by hydraulic pressure, boom angle, boom length, crane maintenance, etc.
- When erecting or stowing the fly jib, be sure to retain it by hand or by other means to prevent its free movement.
- Use the Anti-Two Block (OVERWIND CUTOUT) disable switch when erecting or stowing the extendible fly jib and stowing the hook block. While the switch is pushed, the hoist will not stop, even when an overwind condition occurs.
- The working radius specified in the TADANO LOAD RATING CHARTS for the fly jib apply only if the telescopic boom is extended according to the TADANO LOAD RATING CHARTS. If one or more elements of the telescopic boom are retracted partially or completely, the specified boom angles will be decisive in determining total rated lifting capacities.
- When lifting a load by using the fly jib (auxiliary hoist) and telescopic boom (main hoist) simultaneously, do the following:
  - Select the correct program for the load moment device in accordance with jib length, jib offset angle, counterweight and outrigger base.
  - Before starting the operation, make sure that the weight of the load is within the total rated load for the fly jib.
- Safe Load Indicator (S.L.I.)  
Before working with the telescopic boom or fly jib, make sure that the S.L.I. code is set according to the desired telescoping sequence while the telescopic boom is completely retracted. A change of the telescoping sequence is not permissible when the boom has been partially or fully extended. In order to change the S.L.I. code number, the boom must be fully retracted.
- Working with Single Top  
Operation with the single top is allowed with the main winch and the auxiliary winch. The maximum allowed capacity is limited by the selected S.L.I. code for main boom operation according to existing counterweight and outrigger base at one side and by the single line pull which is limited by hydraulic pressure at the other side.  
For operations with the single top mounted, use the TADANO LOAD RATING CHART for the telescopic boom in accordance with existing counterweight and outrigger base to find the total rated lifting capacity and also select the correct S.L.I. code for the telescopic boom in accordance with the existing counterweight and outrigger base. Find the total rated lifting capacity based on boom length and working radius. From that value, subtract 1,100 lbs and the weights of all lifting equipment used including hook block, sling and other auxiliary lifting devices. The result (<total rated lifting capacity> - <1,100 lbs> - <lifting equipment>) is the total rated lifting capacity for a single top lift.

## DEFINITIONS

1. Working Radius: Horizontal distance from a projection of the axis of rotation to supporting surface before loading to the center of the vertical hoist line or tackle with load applied. The deflection of the boom due to its deadweight and the rated load are taken into account.
2. Loaded Boom Angle: The angle between the boom base section and the horizontal, after lifting the total rated load at the working radius.
3. Working Area: Area measured in a circular arc about the centerline of rotation.
4. Freely Suspended Load: Load hanging free with no direct external force applied except by the hoist line
5. Side Load: Horizontal side force applied to the lifted load either on the ground or in the air.

## Safe Load Indicator

The Safe Load Indicator is intended as an aid to the operator. Under no condition should it be relied upon to replace of Load Rating Charts and Operating Instructions. Sole reliance upon the Safe Load Indicator Aids in place of good operating practice can cause an accident. The operator must exercise caution to assure safety.

## ATF160G-5 Axle weight distribution chart

### 1) Normal traveling condition

	GVW	Axle 1	Axle 2	Axle 3	Axle 4	Axle 5
Base machine with 16.00R25 tires, no counterweight, no fuel , no driver	124,067	24,430	24,617	26,460	24,360	24,200
Add:						
1. 11.0 ton hook ball (in carrier storage)	662	-103	-103	0	433	433
2. 27.5 ton hook block in front	660	573	573	0	-243	-243
3. 69.4 ton hook block in front	1,324	1,147	1,147	0	-485	-485
4. 88.0 ton hook block in front	1,765	1,528	1,528	0	-646	-646
5. 138.0 ton hook block in front	2,645	2,291	2,291	0	-970	-970
6. 200.0 ton hook block at boom head	5,070	4,394	4,394	0	-1,858	-1,858
7. Boom extension (43.3ft) stored on main boom	3,351	1,741	1,741	0	-66	-66
8. Auxiliary winch with cable	3,043	-866	-866	0	2,388	2,388
9. Auxiliary boom point sheave (single top)	187	173	173	0	-80	-80
10. Air conditioning in carrier cab	102	71	71	0	-20	-20
11. Air conditioning in crane cab	106	7	7	0	47	47
12. Tool box at rear	143	-36	-36	0	108	108
13. Additional Hydraulic oil cooler	102	2	2	0	49	49
14. 20.5R25 tires in lieu of 16.00R25	1,035	207	207	207	207	207
15. Towing attachment(190 kN)	176	-44	-44	0	132	132
16. Air & electrical circuits to rear for boom dolly	25	-4	-4	0	17	17
17. Free swing & boom hoist circuit for boom dolly	82	3	3	0	39	39

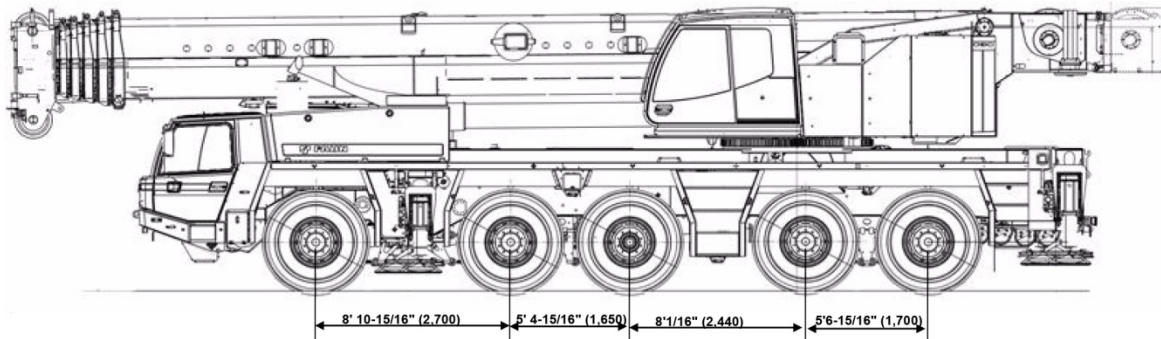

## 2) Traveling with boom dolly

	GVW	Axle 1	Axle 2	Axle 3	Axle 4	Axle 5	Boom Dolly
Base machine with 16.00R25 tires, no counterweight, no fuel, no driver	124,067	19,622	19,810	19,792	20,108	19,947	24,787
Add:							
1. 11.0 ton hook ball (in carrier storage)	662	-103	-103	0	433	433	0
2. 27.5 ton hook block at boom head	660	0	0	0	0	0	660
3. 69.4 ton hook block at boom head	1,324	0	0	0	0	0	1,324
4. 88.0 ton hook block at boom head	1,765	0	0	0	0	0	1,765
5. 138.0 ton hook block at boom head	2,645	0	0	0	0	0	2,645
6. 200.0 ton hook block at boom head	5,070	0	0	0	0	0	5,070
7. Boom extension (43.3ft) stored on main boom	3,351	236	236	0	180	180	2,521
8. 19.69' intermediate sections for boom extension	884	0	0	0	0	0	884
9. Auxiliary winch with cable	3,043	1,335	1,335	0	187	187	0
10. Auxiliary boom point sheave (single top)	187	-12	-12	0	-9	-9	229
11. Air conditioning in carrier cab	102	71	71	0	-20	-20	0
12. Air conditioning in crane cab	106	10	10	0	43	43	0
13. Tool box at rear	143	-36	-36	0	108	108	0
14. Additional Hydraulic oil cooler	102	13	13	0	38	38	0
15. 20.5R25 tires in lieu of 16.00R25	1,035	207	207	207	207	207	0
16. Dolly brackets at boom	154	0	0	0	0	0	154
17. Towing attachment(190 kN)	176	-44	-44	0	132	132	0
18. Air & electrical circuits to rear for boom dolly	25	-4	-4	0	17	17	17
19. Free swing & boom hoist circuit for boom dolly	82	10	10	0	31	31	0

